

JVC

SERVICE MANUAL

CD RECEIVER

KD-S611

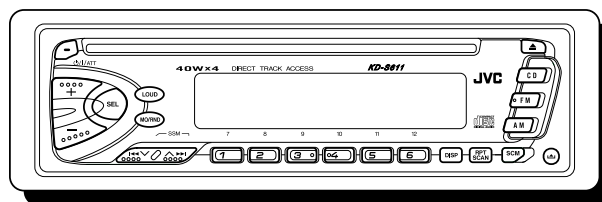
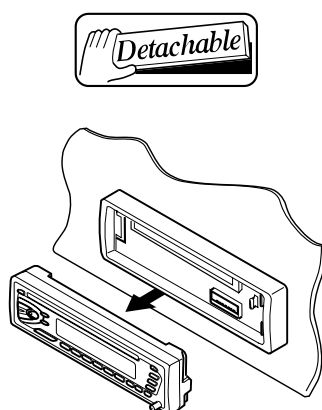

COMPACT
disc
DIGITAL AUDIO

Area Suffix

E ---- Continental Europe

Contents

Safety precaution	1-2	Flow of functional operation	
Preventing static electricity	1-3	unit TOC read	1-12
Important for laser products	1-4	Maintenance of laser pickup	1-14
Location of main parts	1-5	Description of major ICs	1-15
Disassembly method	1-6		
Adjustment method	1-11		

Safety precaution

 **CAUTION** Burrs formed during molding may be left over on some parts of the chassis. Therefore, pay attention to such burrs in the case of performing repair of this system.

 **CAUTION** Please use enough caution not to see the beam directly or touch it in case of an adjustment or operation check.

Preventing static electricity

Electrostatic discharge (ESD), which occurs when static electricity stored in the body, fabric, etc. is discharged, can destroy the laser diode in the traverse unit (optical pickup). Take care to prevent this when performing repairs.

1.1. Grounding to prevent damage by static electricity

Static electricity in the work area can destroy the optical pickup (laser diode) in devices such as DVD players. Be careful to use proper grounding in the area where repairs are being performed.

1.1.1. Ground the workbench

1. Ground the workbench by laying conductive material (such as a conductive sheet) or an iron plate over it before placing the traverse unit (optical pickup) on it.

1.1.2. Ground yourself

1. Use an anti-static wrist strap to release any static electricity built up in your body.

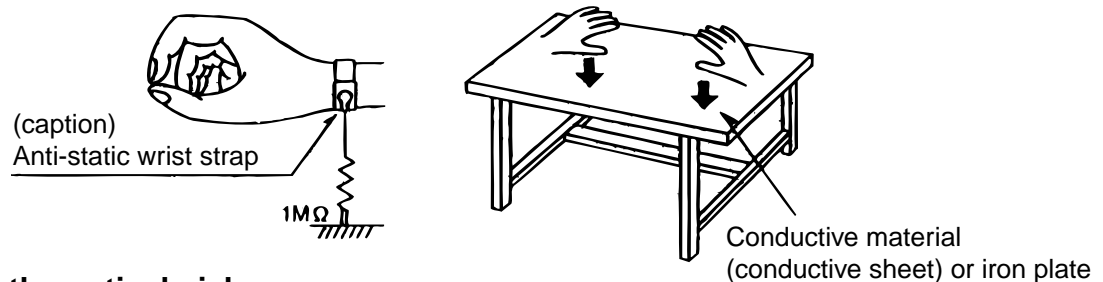

1.1.3. Handling the optical pickup

1. In order to maintain quality during transport and before installation, both sides of the laser diode on the replacement optical pickup are shorted. After replacement, return the shorted parts to their original condition. (Refer to the text.)
2. Do not use a tester to check the condition of the laser diode in the optical pickup. The tester's internal power source can easily destroy the laser diode.

1.2. Handling the traverse unit (optical pickup)

1. Do not subject the traverse unit (optical pickup) to strong shocks, as it is a sensitive, complex unit.
2. Cut off the shorted part of the flexible cable using nippers, etc. after replacing the optical pickup. For specific details, refer to the replacement procedure in the text. Remove the anti-static pin when replacing the traverse unit. Be careful not to take too long a time when attaching it to the connector.
3. Handle the flexible cable carefully as it may break when subjected to strong force.
4. It is not possible to adjust the semi-fixed resistor that adjusts the laser power. Do not turn it

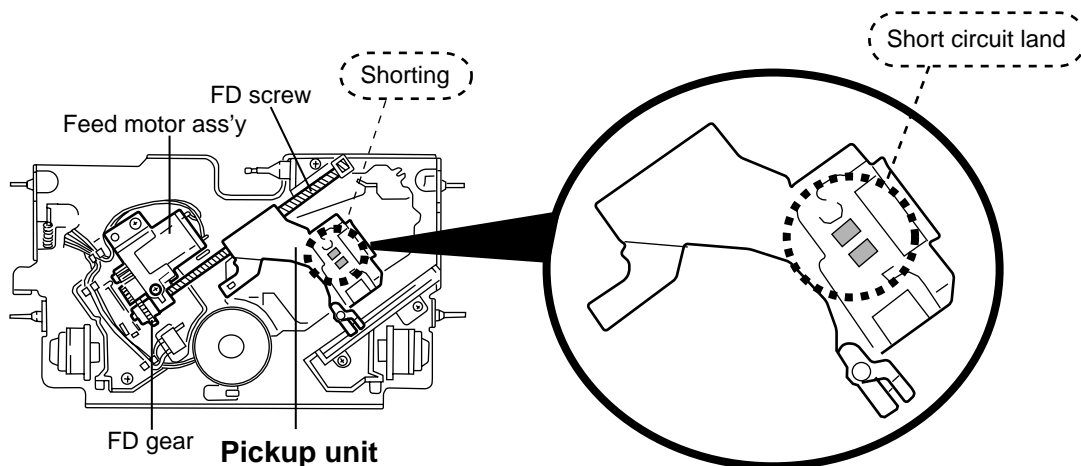

Important for laser products

1.CLASS 1 LASER PRODUCT

2.DANGER : Invisible laser radiation when open and inter lock failed or defeated. Avoid direct exposure to beam.

3.CAUTION : There are no serviceable parts inside the Laser Unit. Do not disassemble the Laser Unit. Replace the complete Laser Unit if it malfunctions.

4.CAUTION : The compact disc player uses invisible laserradiation and is equipped with safety switches which prevent emission of radiation when the drawer is open and the safety interlocks have failed or are defeated. It is dangerous to defeat the safety switches.

5.CAUTION : If safety switches malfunction, the laser is able to function.

6.CAUTION : Use of controls, adjustments or performance of procedures other than those specified herein may result in hazardous radiation exposure.



CAUTION Please use enough caution not to see the beam directly or touch it in case of an adjustment or operation check.

WARNING : Osynlig laserstrålning är denna del är öppnad och spårren är urkopplad. Betrakta ej strålen.

VARO : Avattaessa ja suojalukitus ohitettaessa olet alttiina näkymättömälle lasersäteilylle. Älä katso säteeseen.

ADVARSEL : Usynlig laserstrålning ved åbning , når sikkerhedsafbrydere er ude af funktion. Undgå udsættelse for stråling.

ADVARSEL : Usynlig laserstrålning ved åbning,når sikkerhedsbryteren er avslott. unngå utsettelse for stråling.

REPRODUCTION AND POSITION OF LABELS

WARNING LABEL

**CLASS 1
LASER PRODUCT**

DANGER : Invisible laser radiation when open and interlock or defeated. AVOID DIRECT EXPOSURE TO BEAM (e)

ADVARSEL :Usynlig laserstrålning ved åbning , når sikkerhedsafbrydere er ude af funktion. Undgå udsættelse for stråling. (f)

WARNING : Osynlig laserstrålning är denna del är öppnad och spårren är urkopplad. Betrakta ej strålen. (s)

VARO : Avattaessa ja suojalukitus ohitettaessa olet alttiina näkymättömälle lasersäteilylle. Älä katso säteeseen. (d)



Location of main parts

■ Control unit

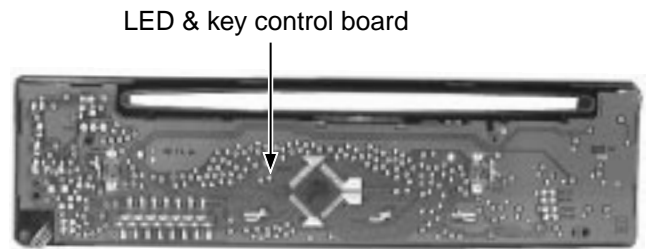
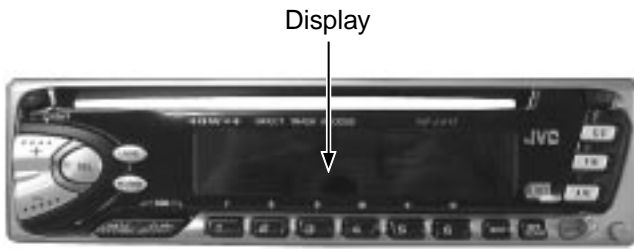

■ Main unit

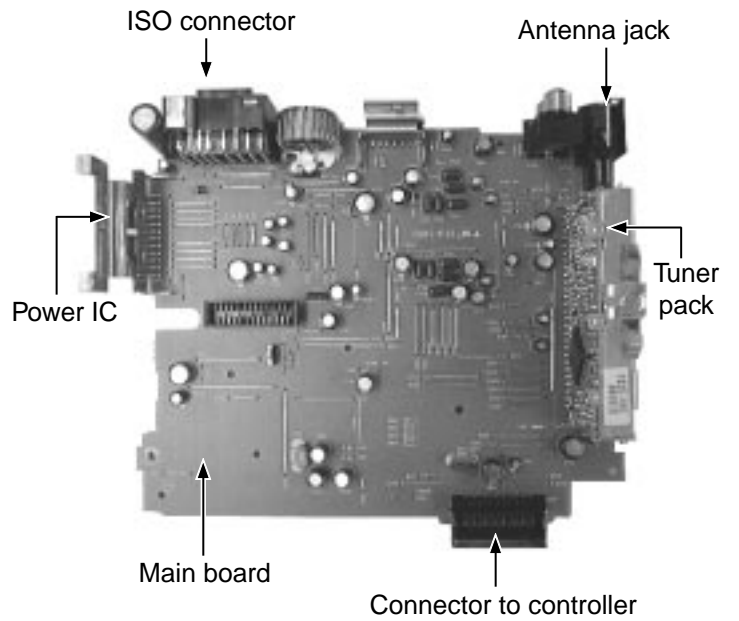
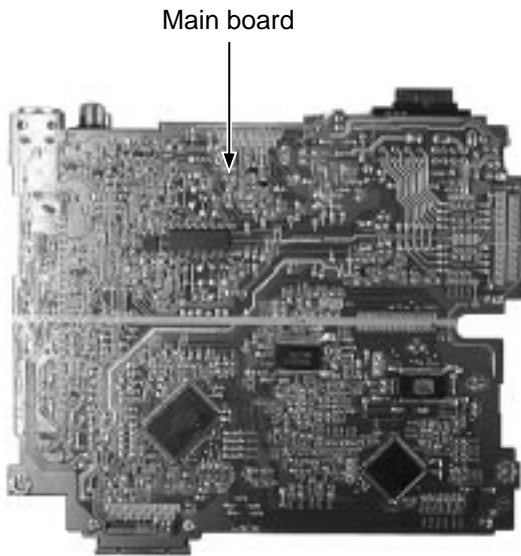

■ CD mechanism

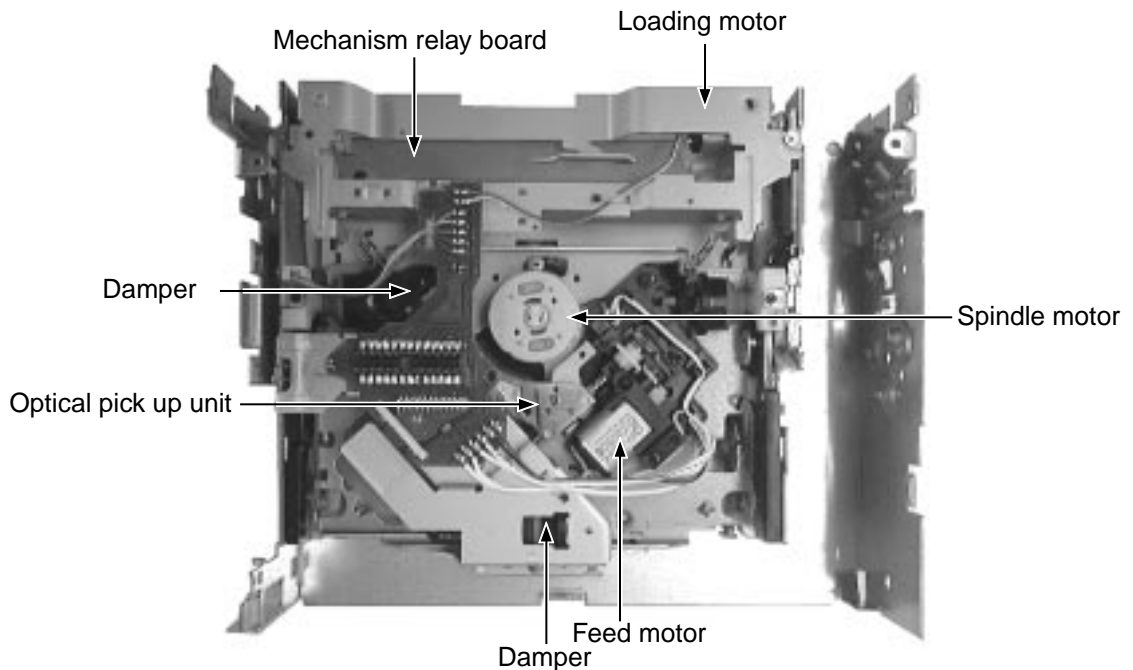

Disassembly method

■ Removing the front panel unit

(See Fig.1)

1. Press the release switch and remove the front panel unit in the direction of the arrow.



Fig.1

■ Removing the front chassis (See Fig.2)

1. Insert a screwdriver to the joints a on the side of the front chassis and two joints b on the right side, then detach the front chassis toward the front side.

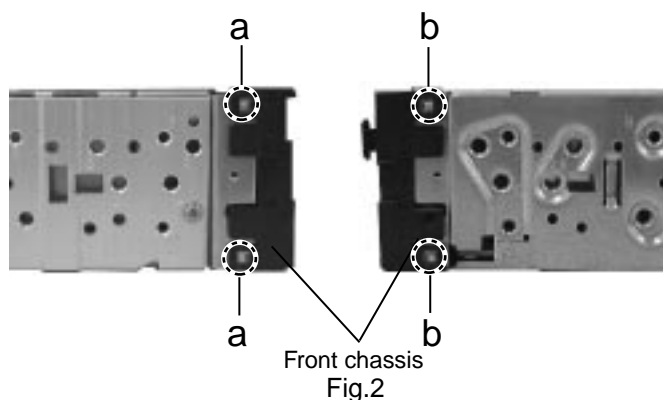

■ Removing the heat sink (See Fig.3)

1. Remove the three screws A attaching the heat sink on the left side of the body, and remove the heat sink.

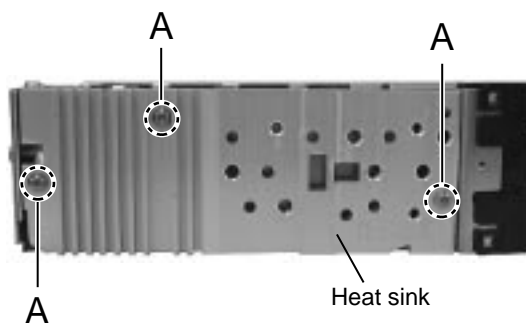

Fig. 3

■ Removing the bottom cover (See Fig.4)

1. Turn the body upside down.
2. Insert a screwdriver to the two joints c and two joints d on both sides of the body and the joint e on the back of the body, then detach the bottom cover from the body.

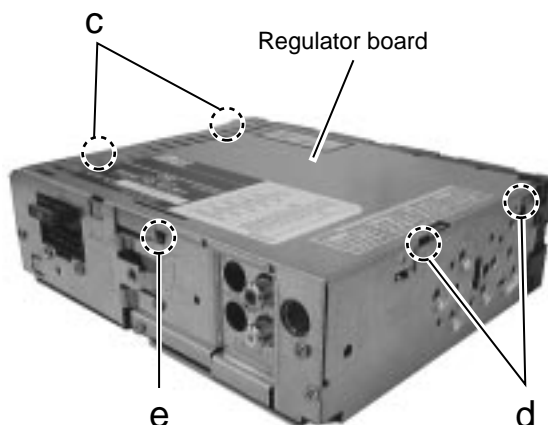

Fig. 4

**■ Removing the main amplifier board
(See Fig.5 and 6)**

1. Remove the front chassis.
2. Remove the bottom cover.
3. Remove the two screws B attaching the main amplifier board assembly on the bottom of the body.
4. Remove the three screws C attaching the main amplifier board assembly on the back of the body.
5. Disconnect connector CN501 on the main amplifier board assembly from the CD mechanism assembly.

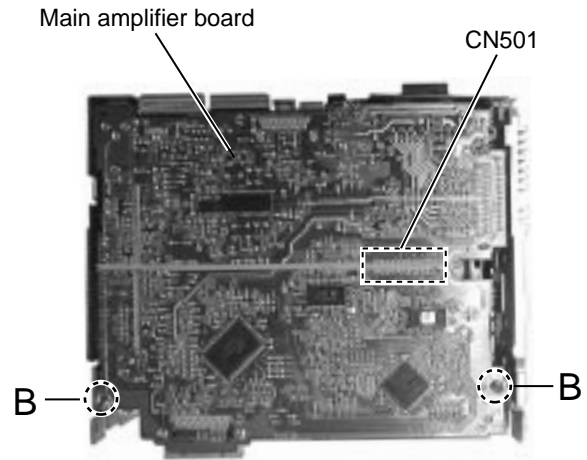

Fig.5

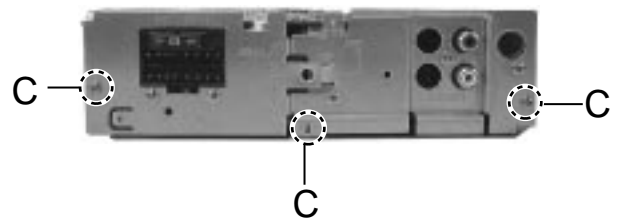

Fig. 6

**■ Removing the CD mechanism assembly
(See Fig.7)**

1. Remove the front chassis.
2. Remove the bottom cover.
3. Remove the main amplifier board assembly.
4. Remove the three screws D attaching the CD mechanism assembly from the top cover.

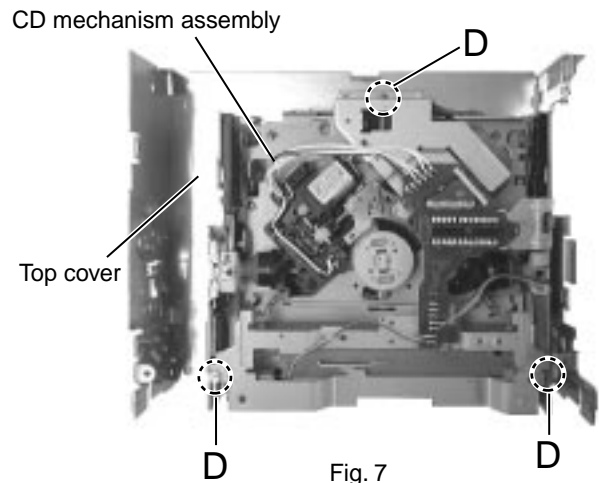

Fig. 7

**■ Removing the control switch board
(See Fig.8 and 9)**

1. Remove the front chassis.
2. Remove the four screws E attaching the rear cover on the back of the front panel unit.
3. Remove the control switch board from the front panel unit.

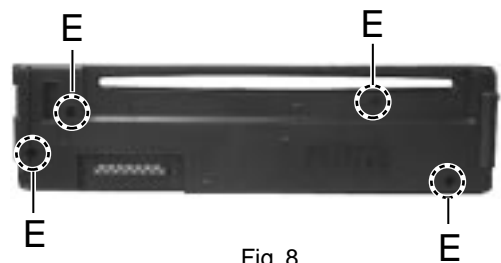

Fig. 8

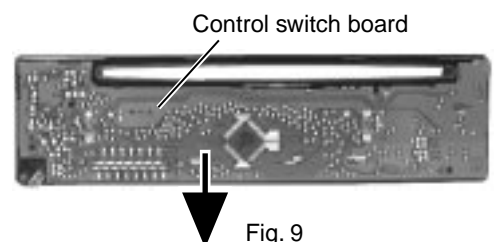

Fig. 9

■ **Removing the CD mechanism control board(See Fig.1 and 2)**

Unsolder the part f and g on the CD mechanism control board.

Remove the stator fixing the CD mechanism control board and the damper bracket (To remove the stator smoothly, pick up the center part).

Remove the screw F attaching the CD mechanism control board.

Remove the CD mechanism control board in the direction of the arrow while releasing it from the two damper bracket slots i and the front bracket slot j.

Disconnect the flexible wire from connector on the pickup unit.

ATTENTION: Turn the FD gear in the direction of the arrow to move the entire pickup unit to the appropriate position where the flexible wire of the CD mechanism unit can be disconnected easily (Refer to Fig.2).

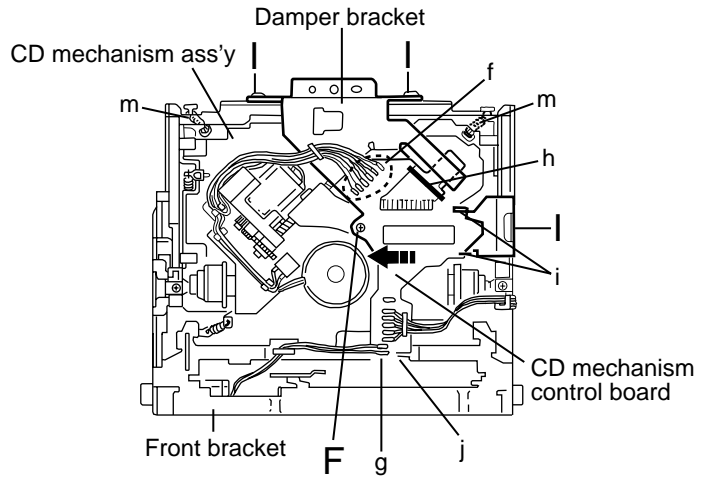

Fig.1

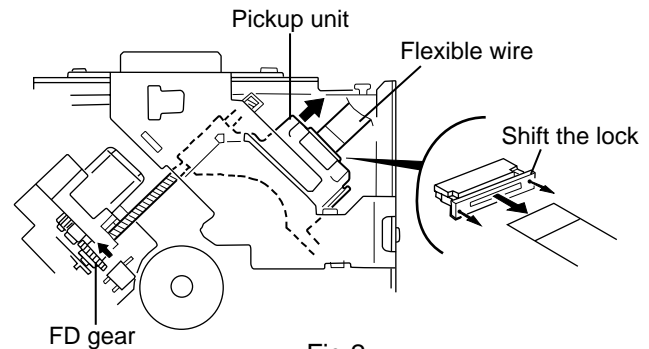

Fig.2

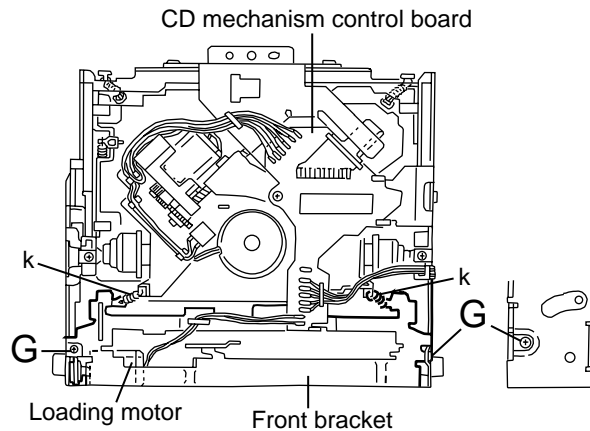

Fig.3

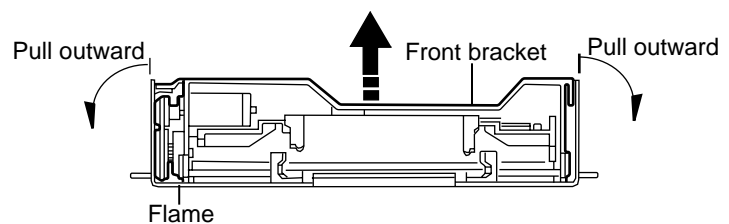

Fig.4

**■ Removing the loading motor
(See Fig.3 to 5)**

• Prior to performing the following procedure, remove the CD mechanism control board.

1. Remove the two springs k attaching the CD mechanism ass'y and the front bracket.
2. Remove the two screws G and the front bracket while pulling the flame outward.
3. Remove the belt and the screw H from the loading motor.

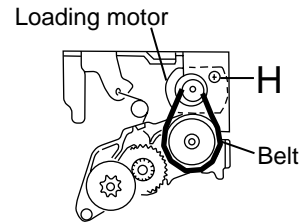

Fig.5

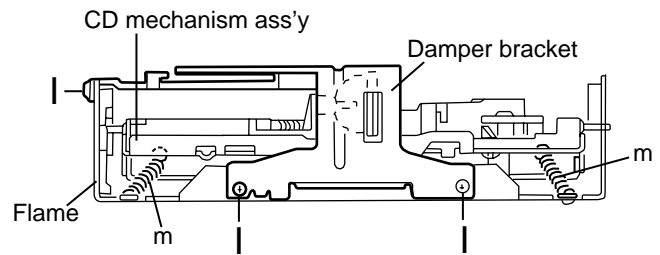

Fig.6

**■ Removing the CD mechanism ass'y
(See Fig.1, 6 to 9)**

• Prior to performing the following procedure, remove the CD mechanism control PWB and the front bracket (loading motor).

1. Remove the three screws I and the damper bracket.
2. Raise the both sides fix arms and move the fix plates in the direction of the arrow to place the four shafts I as shown in Fig.8 and 9.
3. Remove the CD mechanism ass'y and the two springs m attaching the flame.
4. Remove the two screws J and both sides rear damper brackets from the dampers. Detach the CD mechanism ass'y from the left side to the right side.

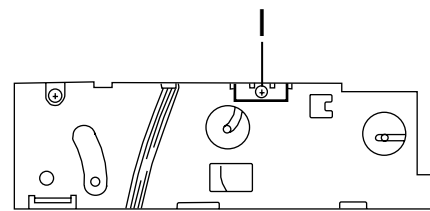

Fig.7

ATTENTION: The CD mechanism ass'y can be removed if only the rear damper bracket on the left side is removed.

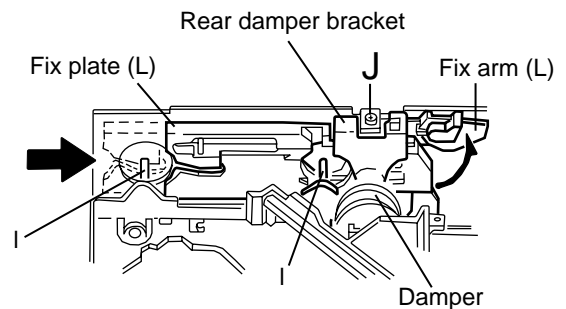

Fig.8

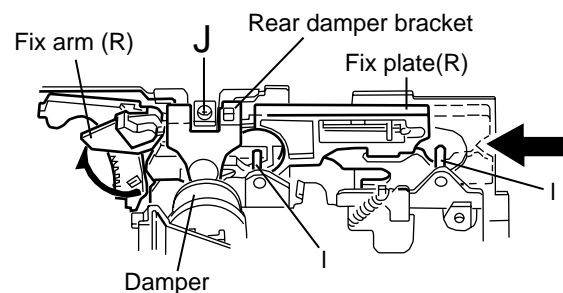

Fig.9

■ Removing the feed motor ass'y
(See Fig.10)

- Prior to performing the following procedure, remove the CD mechanism control board, the front bracket (loading motor) and the CD mechanism ass'y.

1. Remove the two screws K and the feed motor ass'y.

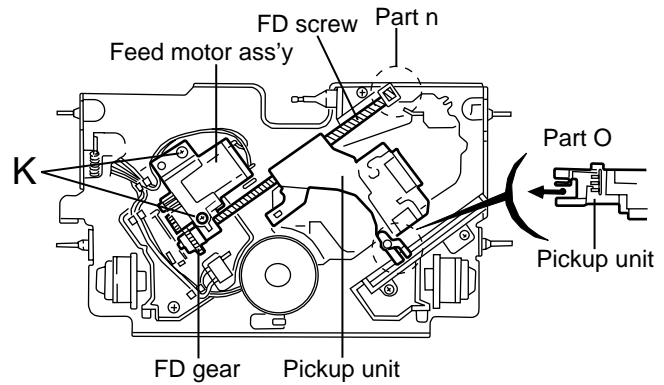

Fig.10

■ Removing the pickup unit
(See Fig.10 and 11)

- *Prior to performing the following procedure, remove the CD mechanism control board, the front bracket (loading motor), the CD mechanism ass'y and the feed motor ass'y.

1. Detach the FD gear part of the pickup unit upward. Then remove the pickup unit while pulling out the part n of the FD screw.

ATTENTION: When reattaching the pickup unit, reattach the part o of the pickup unit, then the part n of the FD screw.

2. Remove the screw L attaching the nut push spring plate and the pickup mount nut from the pickup unit. Pull out the FD screw.

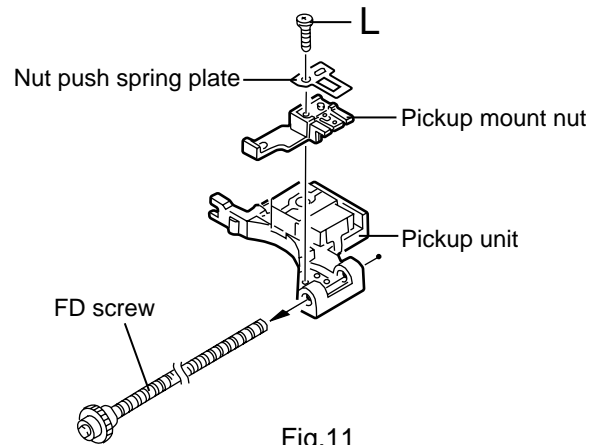

Fig.11

■ Removing the spindle motor
(See Fig.12 and 13)

- Prior to performing the following procedure, remove the CD mechanism control board, the front bracket (loading motor), the CD mechanism ass'y and the feed motor ass'y.

1. Turn up the CD mechanism ass'y and remove the two springs p on both sides of the clamber arms. Open the clamber arm upward.

2. Turn the turn table, and remove the two screws M and the spindle motor.

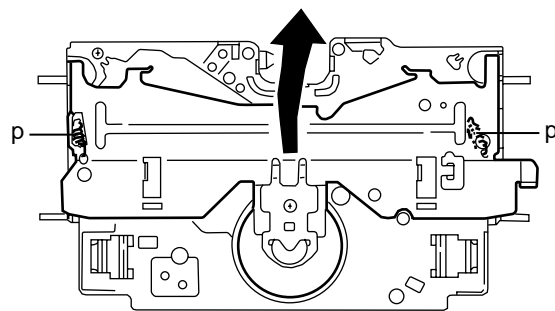

Fig.12

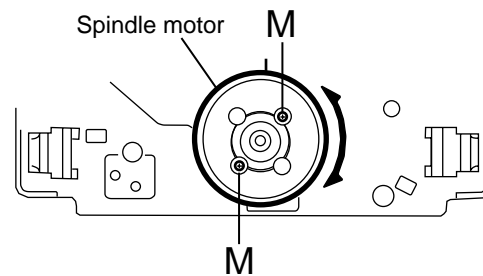

Fig.13

Adjustment method

■ Test instruments required for adjustment

1. Digital oscilloscope (100MHz)
2. AM Standard signal generator
3. FM Standard signal generator
4. Stereo modulator
5. Electric voltmeter
6. Digital tester
7. Tracking offset meter
8. Test Disc JVC :CTS-1000
9. Extension cable for check
EXTGS004-26P × 1

■ Standard volume position

Balance and Bass & Treble volume : Indication "0"
Loudness : OFF

■ Frequency Band

FM 87.5MHz ~ 108.0MHz
MW 522kHz ~ 1620 kHz
LW 144kHz ~ 279kHz

■ Dummy load

Exclusive dummy load should be used for AM, and FM. For FM dummy load, there is a loss of 6dB between SSG output and antenna input. The loss of 6dB need not be considered since direct reading of figures are applied in this working standard.

■ Standard measuring conditions

Power supply voltage DC14.4V(10.5~16V)
Load impedance 4 Ω (2 Speakers connection)
Line out load impedance 20k Ω
Output Level Line out 2.0V (Vol. MAX)

■ How to connect the extension cable for adjusting

* The cardboard is cut in a suitable size.
uses for the insulation stand of mechanism.

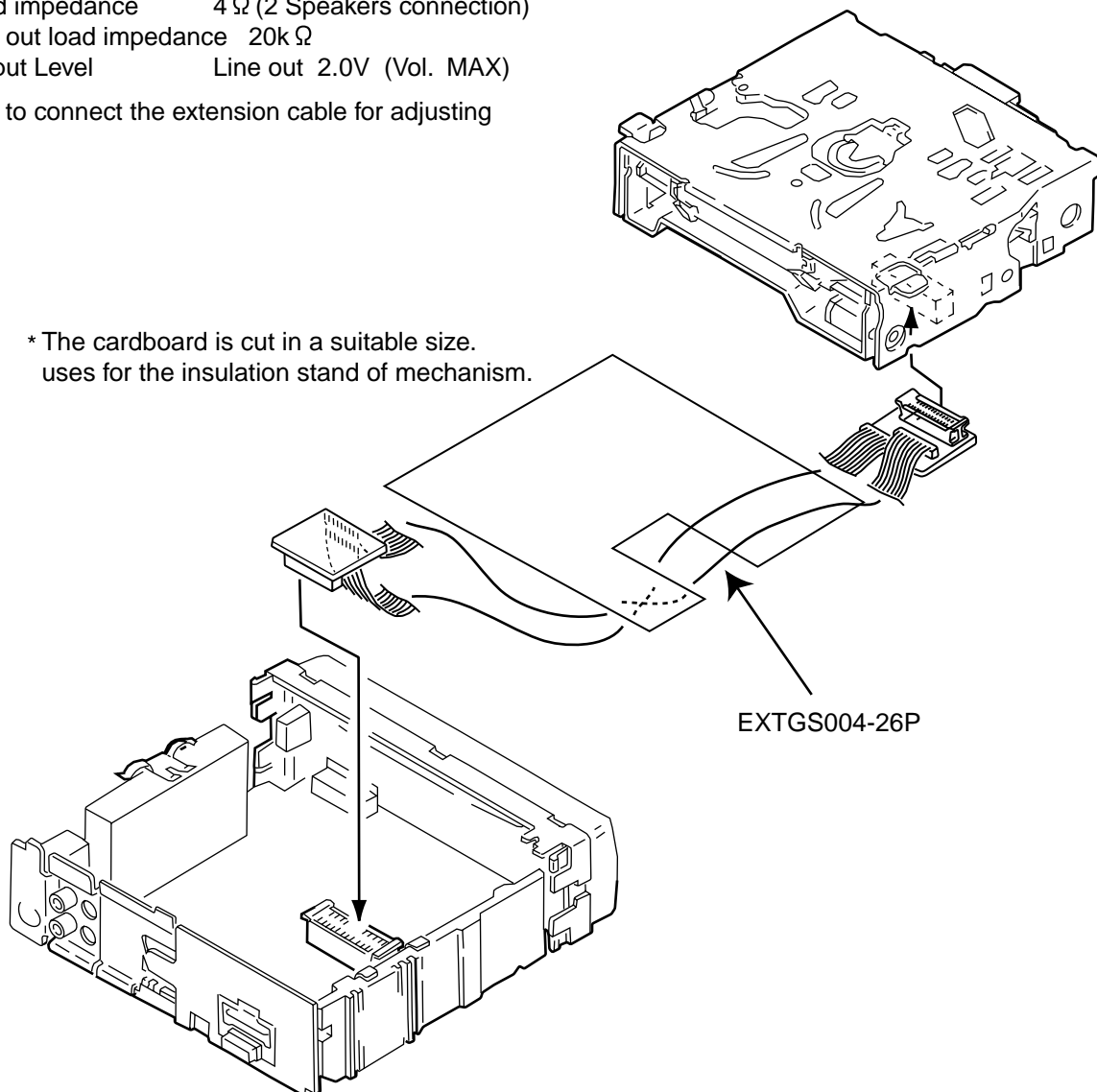

Flow of functional operation until TOC read

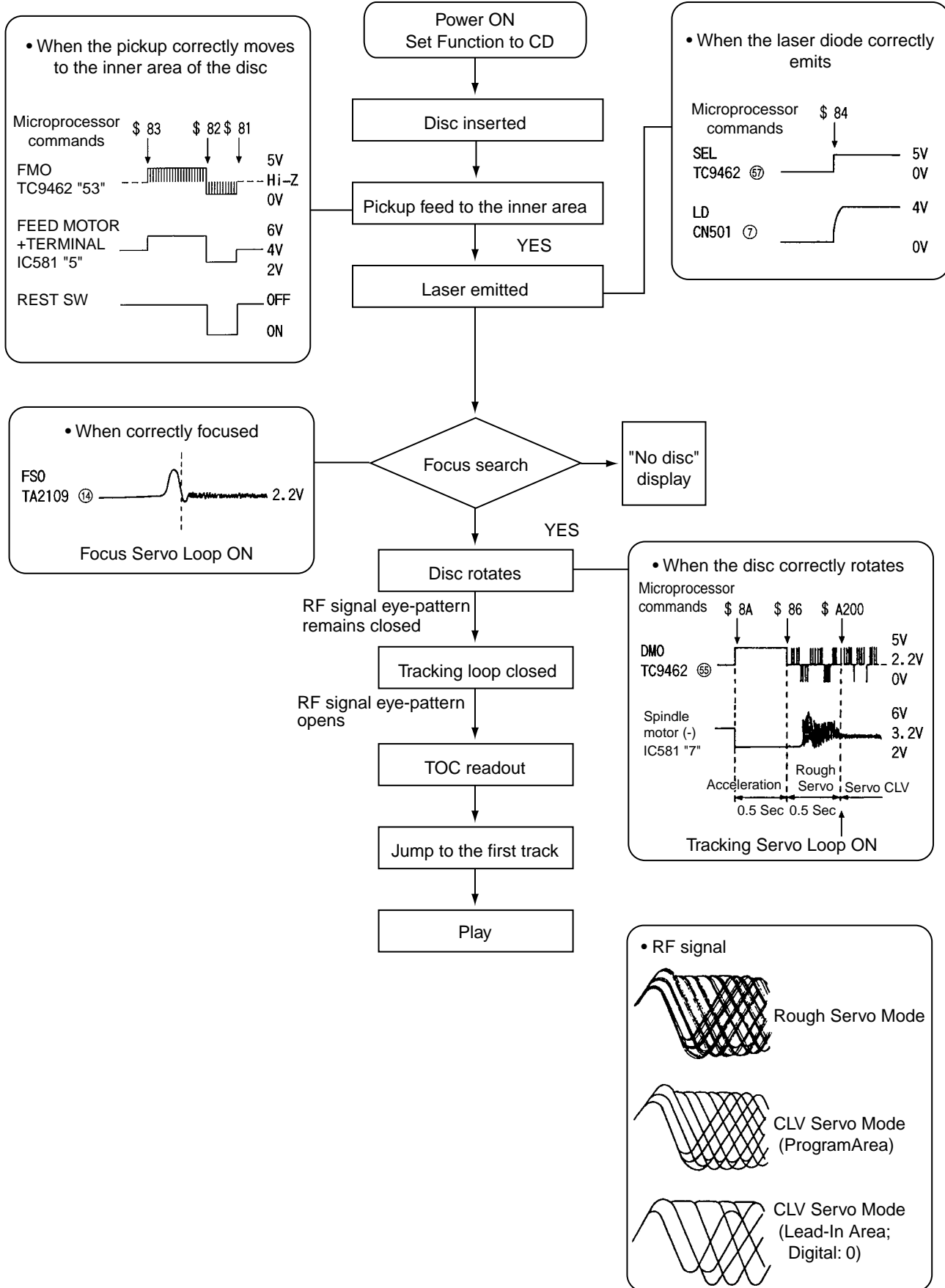

■ Feed Section

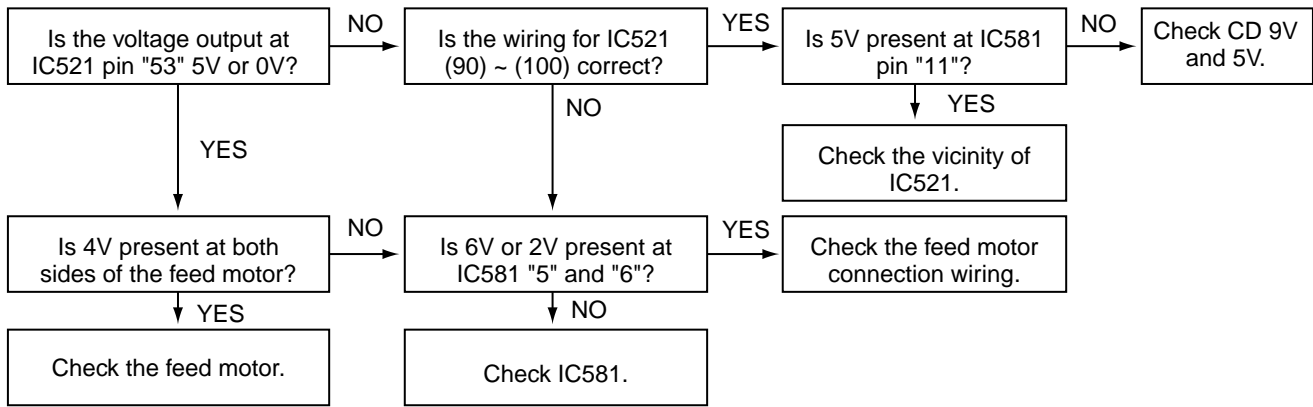

■ Focus Section

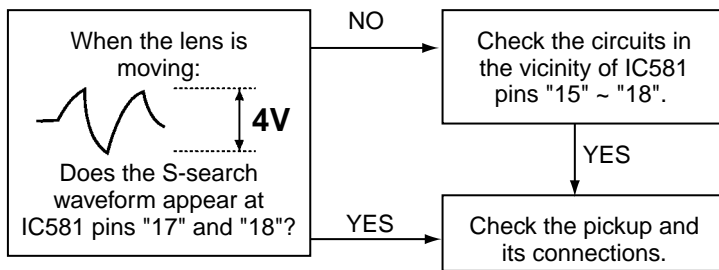

■ Spindle Section

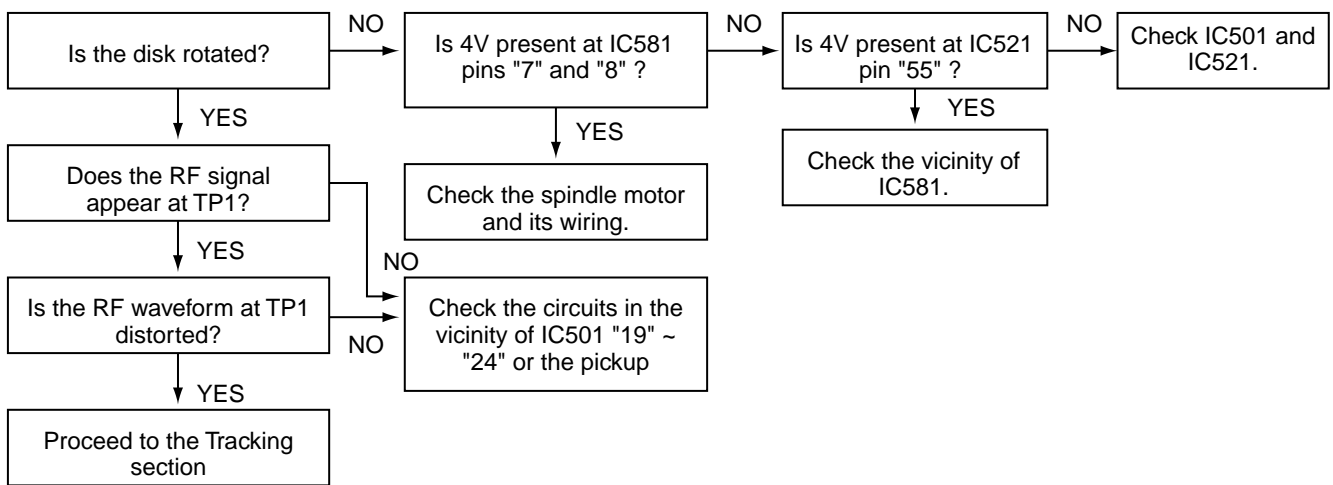

■ Tracking Section

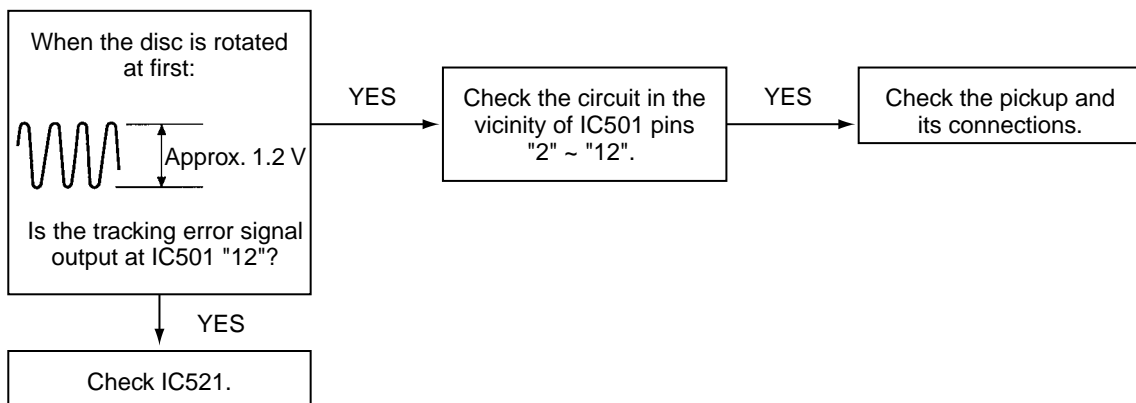

Maintenance of laser pickup

(1) Cleaning the pick up lens
 Before you replace the pick up, please try to clean the lens with a alcohol soaked cotton swab.

(2) Life of the laser diode
 When the life of the laser diode has expired, the following symptoms will appear.

(1) The level of RF output (EFM output:amplitude of eye pattern) will be low.

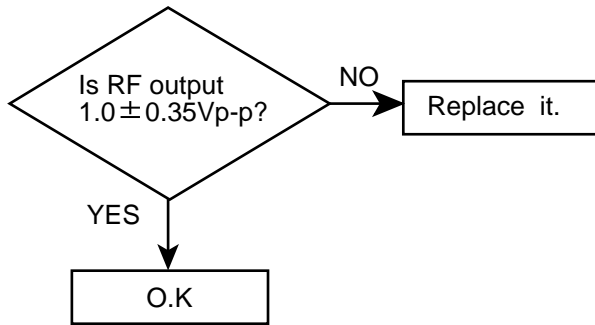

Replacement of laser pickup

(3) Semi-fixed resistor on the APC PC board
 The semi-fixed resistor on the APC printed circuit board which is attached to the pickup is used to adjust the laser power. Since this adjustment should be performed to match the characteristics of the whole optical block, do not touch the semi-fixed resistor.
 If the laser power is lower than the specified value, the laser diode is almost worn out, and the laser pickup should be replaced.
 If the semi-fixed resistor is adjusted while the pickup is functioning normally, the laser pickup may be damaged due to excessive current.

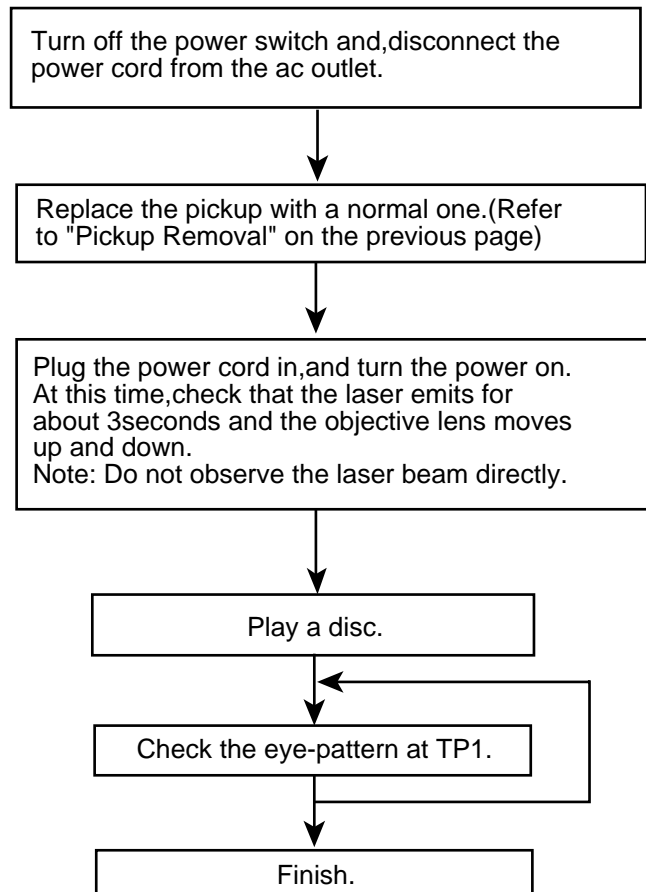

Description of major ICs

TEA6320T-X(IC301) : E.volume

1.Terminal Layout

2.Block Diagram

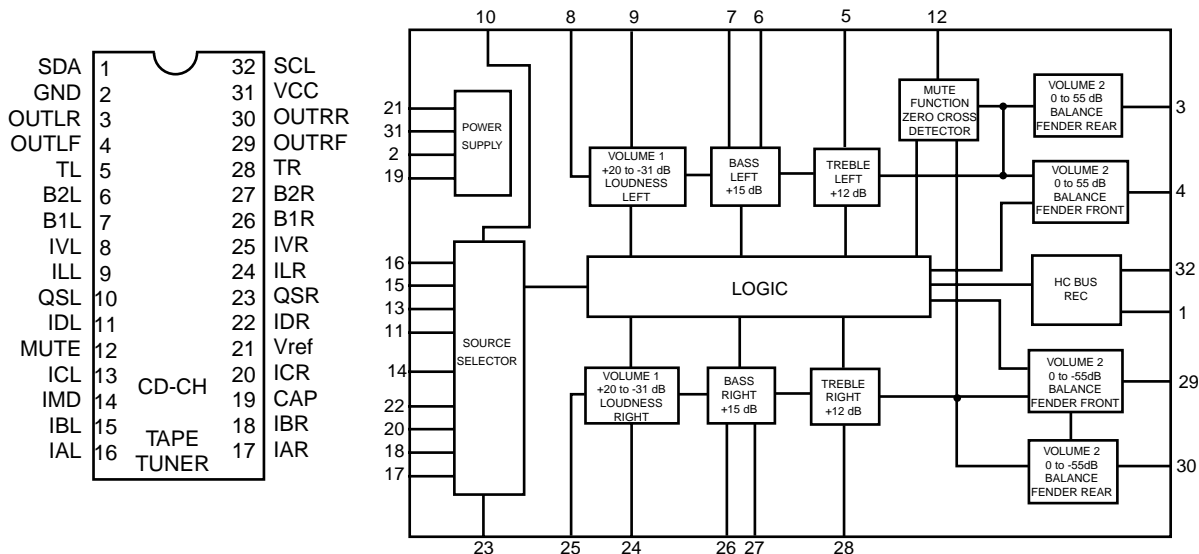

3.Pin Functions

Pin No.	Symbol	I/O	Functions	Pin No.	Symbol	I/O	Functions
1	SDA	I/O	Serial data input/output.	17	IAR	I	Input A right source.
2	GND	-	Ground.	18	IBR	I	Input B right source.
3	OUTLR	O	output left rear.	19	CAP	-	Electronic filtering for supply.
4	OUTLF	O	output left front.	20	ICR	I	Input C right source.
5	TL	I	Treble control capacitor left channel or input from an external equalizer.	21	Vref	-	Reference voltage (0.5Vcc)
6	B2L	-	Bass control capacitor leftchannel or output to an external equalizer.	22	IDR	-	Not used
7	B1L	-	Bass control capacitor left channel.	23	QSR	O	Output source selector right channel.
8	IVL	I	Input volume 1. left control part.	24	ILR	I	Input loudness right channel.
9	ILL	I	Input loudness. left control part.	25	IVR	I	Input volume 1. right control part.
10	QSL	O	Output source selector. left channel.	26	B1R	-	Bass control capacitor right channel
11	IDL	-	Not used	27	B2R	O	Bass control capacitor right channel or output to an external equalizer.
12	MUTE	-	Not used	28	TR	I	Treble control capacitor right channel or input from an external equalizer.
13	ICL	I	Input C left source.	29	OUTRF	O	Output right front.
14	IMO	-	Not used	30	OUTRR	O	Output right rear.
15	IBL	I	Input B left source.	31	Vcc	-	Supply voltage.
16	IAL	I	Input A left source.	32	SCL	I	Serial clock input.

■ AN8806SB-W (IC501) : RF&Servo amp.

1.Pin layout

PD	1	36	PDAC
LD	2	35	PDBD
LDON	3	34	PDF
LDP	4	33	PDE
VCC	5	32	PDER
RF-	6	31	PDFR
RF OUT	7	30	TBAL
RF IN	8	29	FBAL
C.AGC	9	28	EF-
ARF	10	27	EF OUT
C.ENV	11	26	TE-
C.EA	12	25	TE OUT
CS BDO	13	24	CROSS
BDO	14	23	TE BPF
CS BRT	15	22	VDET
OFTR	16	21	LD OFF
/NRFDET	17	20	VREF
GND	18	19	ENV

2.Block diagram

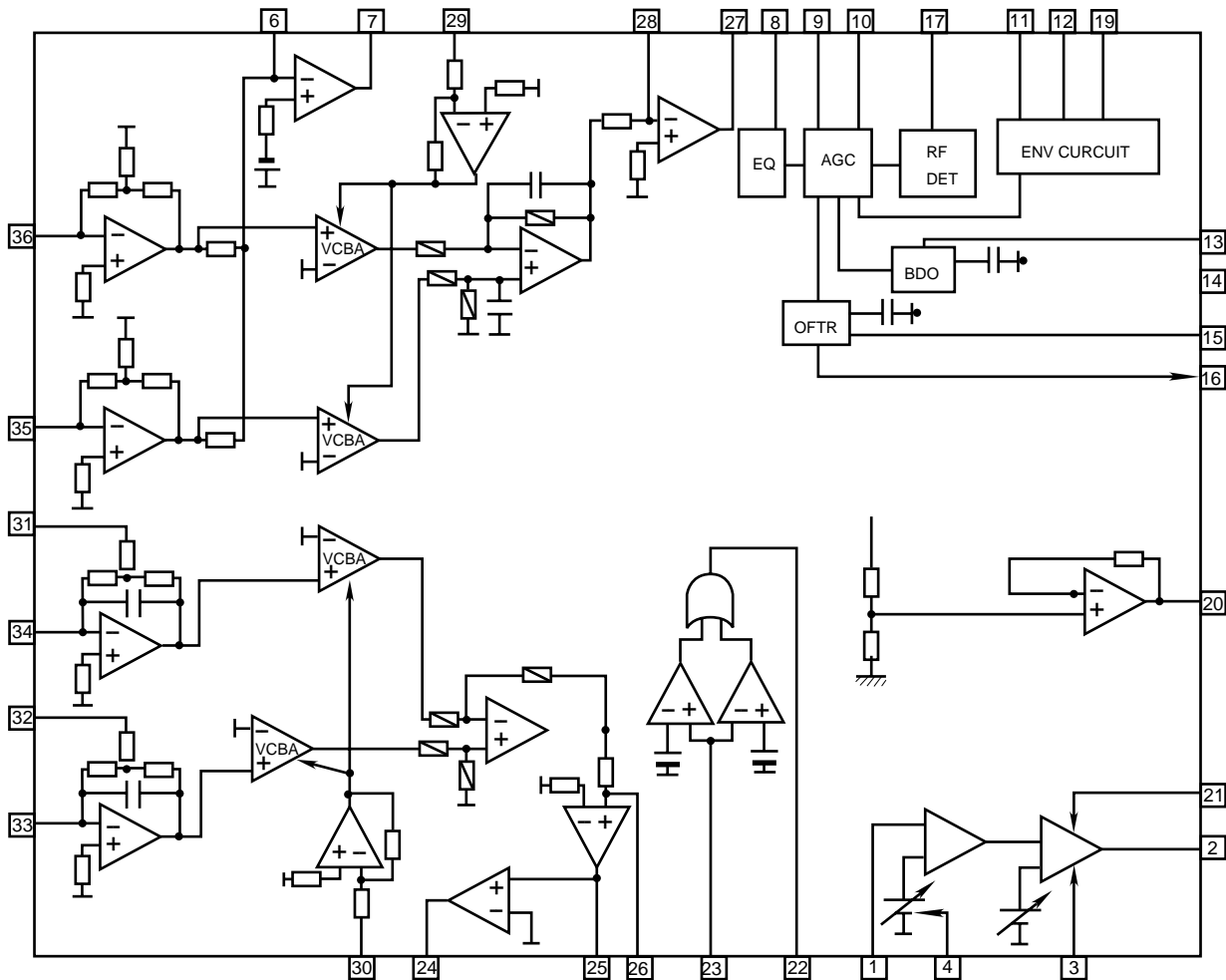

3. Pin function

AN8806SB-W

Pin No.	Symbol	I/O	Description
1	PD	I	APC amp input terminal
2	LD	O	APC amp output terminal
3	LD ON	I	APC ON/OFF control terminal
4	LDP	--	Connect to ground
5	VCC	--	Power supply
6	RF-	I	Inverse input pin for RF amp
7	RF OUT	O	RFamp output
8	RF IN	I	RF input
9	C.AGC	I/O	Connecting pin of AGC loop filter
10	ARF	O	RF output
11	C.ENV	I/O	A capacitor is connected to this terminal to detect the envelope of RF signal
12	C.EA	I/O	A capacitor is connected to this terminal to detect the envelope of RF signal
13	CS BDO	I/O	A capacitor is connected to detect the lower envelope of RF signal
14	BDO	O	BDO output pin
15	CS BRT	I/O	A capacitor is connected to detect the lower envelope of RF signal
16	OFTR	O	Of-track status signal output
17	/NRFDET	O	RF detection signal output
18	GND	--	Ground
19	ENV	O	Envelope output
20	VREF	O	Reference voltage output
21	LD OFF	--	Connect to ground
22	VDET	O	Vibration detection signal output
23	TE BPF	I	Input pin of tracking error through BPF
24	CROSS	O	Tracking error cross output
25	TE OUT	O	Tracking error signal output
26	TE-	I	Inverse input pin for tracking error amp
27	FE OUT	O	Output pin of focus error
28	FE-	I	Inverse input pin for focus error amp
29	FBAL	I	Focus balance control
30	TBAL	I	Tracking balance control
31	PDFR	I/O	F I-V amp gain control
32	PDER	I/O	E I-V amp gain control
33	PDF	I	I-V amp input
34	PDE	I	I-V amp input
35	PD BD	I	I-V amp input
36	PD AC	I	I-V amp input

■ MN35510(IC561):Digital servo & digital signal processor

1. Terminal Layout

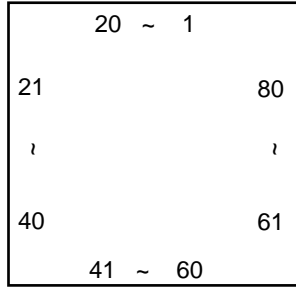

2. Block Diagram

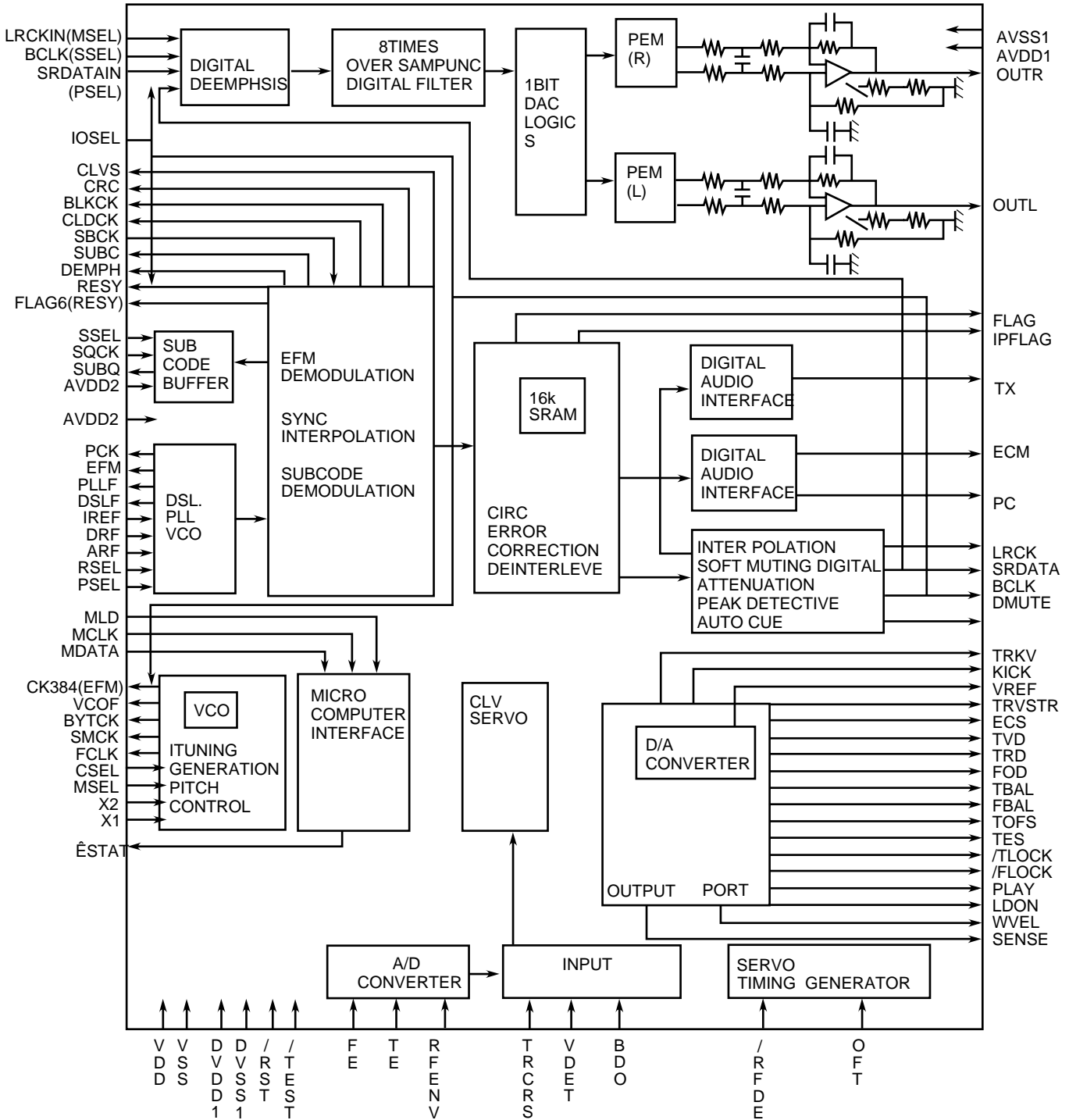

3. Description

Pin No.	symbol	I/O	Description	Pin No.	symbol	I/O	Description
1	BCLK	O	Not used	41	TES	O	Tracking error shunt signal output(H:shunt)
2	LRCK	O	Not used	42	PLAY	—	Not used
3	SRDATA	O	Not used	43	WVEL	—	Not used
4	DVDD1	—	Power supply (Digital)	44	ARF	I	RF signal input
5	DVSS1	—	Connected to GND	45	IREF	I	Reference current input pin
6	TX	O	Digital audio interface output	46	DRF	I	Bias pin for DSL
7	MCLK	I	Micom command clock signal input (Data is latched at signal's rising point)	47	DSL F	I/O	Loop filter pin for DSL
8	MDATA	I	Micom command data input	48	PLL F	I/O	Loop filter pin for PLL
9	MLD	I	Micom command load signal input	49	VCOF	—	Not used
10	SENSE	O	Sence signal output	50	AVDD2	—	Power supply(Analog)
11	FLOCK	O	Focus lock signal output Active :Low	51	AVSS2	—	Connected to GND(Analog)
12	TLOCK	O	Tracking lock signal output Active :Low	52	EFM	—	Not used
13	BLKCK	O	sub-code - block - clock signal output	53	PCK	—	Not used
14	SQCK	I	Outside clock for sub-code Q resister input	54	PDO	—	Not used
15	SUBQ	O	Sub-code Q -code output	55	SUBC	—	Not used
16	DMUTE	—	Connected to GND	56	SBCK	—	Not used
17	STATUS	O	Status signal (CRC,CUE,CLVS,TTSTOP,ECLV,SQOK)	57	VSS	—	Connected to GND(for X'tal oscillation circuit)
18	RST	I	Reset signal input (L:Reset)	58	XI	I	Input of 16.9344MHz X'tal oscillation circuit
19	SMCK	—	Not used	59	X2	O	Output of X'tal oscillation circuit
20	PMCK	—	Not used	60	VDD	—	Power supply(for X'tal oscillation circuit)
21	TRV	O	Traverse enforced output	61	BYTCK	—	Not used
22	TVD	O	Traverse drive output	62	CLDCK	—	Not used
23	PC	—	Not used	63	FLAG	—	Not used
24	ECM	O	Spindle motor drive signal (Enforced mode output) 3-State	64	IPPLAG	—	Not used
25	ECS	O	Spindle motor drive signal (Servo error signal output)	65	FLAG	—	Not used
26	KICK	O	Kick pulse output	66	CLVS	—	Not used
27	TRD	O	Tracking drive output	67	CRC	—	Not used
28	FOD	O	Focus drive output	68	DEMPH	—	Not used
29	VREF	I	Reference voltage input pin for D/A output block (TVD,FOD,FBA,TBAL)	69	RESY	—	Not used
30	FBAL	O	Focus Balance adjust signal output	70	IOSEL	—	pull up
31	TBAL	O	Tracking Balance adjust signal output	71	TEST	—	pull up
32	FE	I	Focus error signal input(Analog input)	72	AVDD1	—	Power supply(Digital)
33	TE	I	Tracking error signal input(Analog input)	73	OUT L	O	Lch audio output
34	RF ENV	I	RF envelope signal input(Analog input)	74	AVSS1	—	Connected to GND
35	VDET	I	Vibration detect signal input(H:detect)	75	OUT R	O	Rch audio output
36	OFT	I	Off track signal input(H:off track)	76	RSEL	—	pull up
37	TRCRS	I	Track cross signal input	77	CSEL	—	Connected to GND
38	RFDET	I	RF detect signal input(L:detect)	78	PSEL	—	Connected to GND
39	BDO	I	BDO input pin(L:detect)	79	MSEL	—	Connected to GND
40	LDON	O	Laser ON signal output(H:on)	80	SSEL	—	Pull up

LA6557H-X(IC541) : Servo BTL driver

1. Block diagram

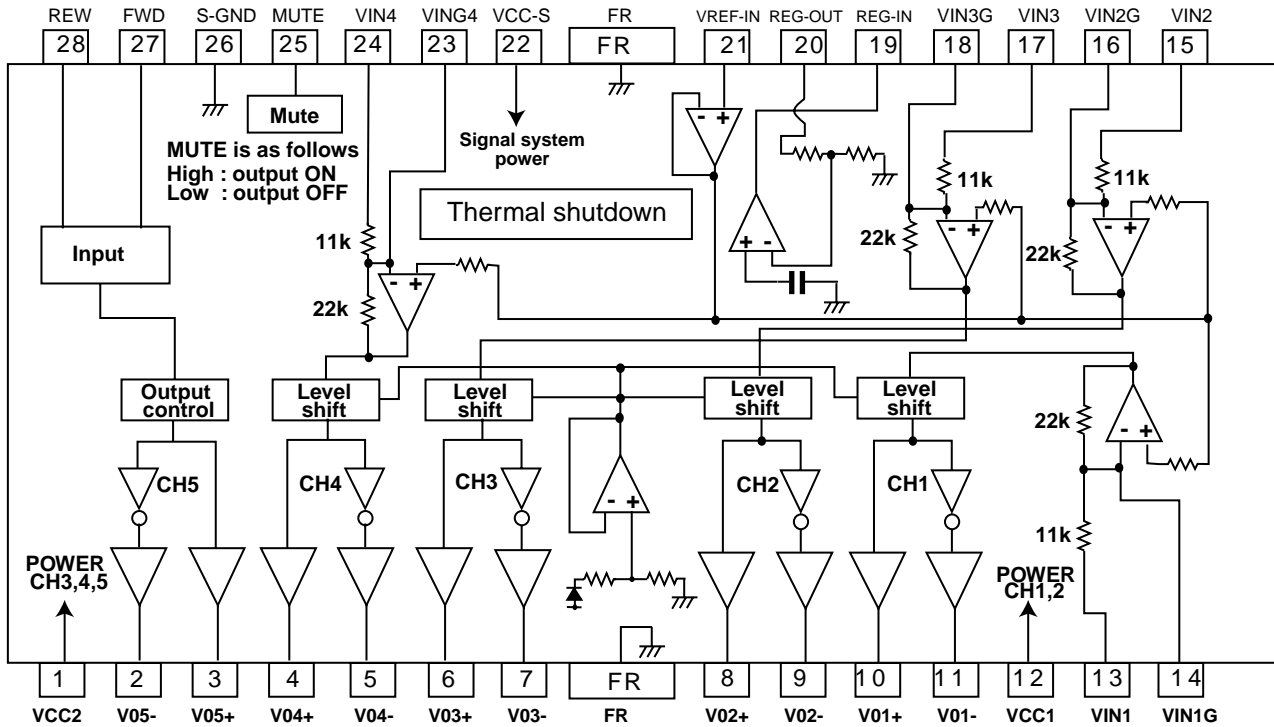

2. Pin function

Pin No.	Pin Name	Description
1	VCC2	Power for channels 3, 4, and 5 (VCC1 and VCC-S short-circuited)
2	V05-	Loading output (-)
3	V05+	Loading output (+)
4	V04+	Output pin (+) for channel 4
5	V04-	Output pin (-) for channel 4
6	V03+	Output pin (+) for channel 3
7	V03-	Output pin (-) for channel 3
8	V02+	Output pin (+) for channel 2
9	V02-	Output pin (-) for channel 2
10	V01+	Output pin (+) for channel 1
11	V01-	Output pin (-) for channel 1
12	VCC1	Power for channels 1 and 2 (BTL), (VCC-S and VCC2 short-circuited)
13	VIN1	Input pin for channel 1
14	VIN1G	Input pin for channel 1 (for gain control)
15	VIN2	Input pin for channel 2
16	VIN2G	Input pin for channel 2 (for gain control)
17	VIN3	Input pin for channel 3
18	VIN3G	Input pin for channel 3 (for gain control)
19	REG-IN	Regulator pin (External PNP base)
20	REG-OUT	Regulator pin (External PNP collector)
21	VRFE-IN	Reference voltage input pin
22	VCC-S	Signal system power (VCC1 and VCC2 short-circuited)
23	VIN4G	Input pin for channel 4 (for gain control)
24	VIN4	Input pin for channel 4
25	MUTE	Output ON/OFF, channels 1 to 4 (BTL AMP)
26	S-GND	Signal system GND
27	FWD	5CH(VL0) Output change pin (FWD), Logic input for loading block
28	REV	5CH(VL0) Output change pin (REW), Logic input for loading block

■ LC72366-9989 (IC801) : Main micon

1. Pin layout

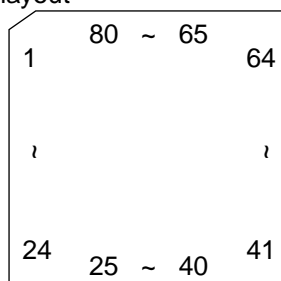

2. Pin function

Pin No.	Symbol	Function	Pin No.	Symbol	Function
1	XIN	4.5MHz crystal oscillation	41	CD ON	CD 8V supply on
2	TEST2	Connect to ground	42	RELAY	5V power control
3	J BUS SI	J-BUS signal data input (to 74HC126)	43	BBE CTL	No use
4	J BUS SO	J-BUS signal data output (to 74HC126)	44	BEEP	No use
5	J BUS SCK	J-BUS output clock signal (to 74HC126)	45	SW4	
6	J BUS I/O CONT	J-BUS I/O control	46	SW1	CD mechanism switch 1 for disc in, 8cm disc
7	SUBQ	CD LSI subcode data input	47	SW3	CD mecha. switch 3 for disc present, loading end
8		No use	48	REST	CD pickup rest position
9	SQCK	CD LSI subcode clock	49	JOG0	Rotary encoder input 0
10	RESET	Micon reset pin	50	JOG1	Rotary encoder input 1
11	LCD SI	No use	51	CD SENSE	CD LSI sense signal
12	LCD SO	LCD driver data output	52	STATUS	CD LSI status signal
13	LCDSCK	LCD driver clock signal	53	P.SAVE2	Power save 2 : +B detect
14	LCD CE	LCD driver chip enable port	54	SD/ST	Station detection, Stereo indication
15	FM ILLUMI	No use	55	REMOCON	Remocon input
16	AM ILLUMI	No use	56	J BUS INT	J-BUS interrupt
17	CD ILLUMI	No use	57	BAND	FM/AM band selection
18	DIMMER OUT	No use	58	MONO	FM mono selection
19	LM0	CD loading motor output	59	IFRQ/AGC	During FM auto search, IF request output H after SD
20	LM1	CD loading motor output			detected. During AM auto search, AGC output.
21		No use	60	MUTE	Muting switch
22		No use	61	LEVEL	Level meter input
23		No use	62	S METER	S meter input
24	KS2	No use	63	KEY CHANGE	Connect to ground
25	KS1	No use	64	KEY2	Key 2 data input (AD)
26	KS0	Output for initial setting diode matrix	65	KEY1	Key 1 data input (AD)
27	DETACH	Front panel detect	66	KEY0	Key 0 data input (AD)
28	K2	No use	67	P.SAVE1	Power save 1, ACC power detect
29	K1	Input for initial setting diode matrix	68	SENSE	Voltage sense
30	K0	Input for initial setting diode matrix	69		No use
31	Vdd	5V power supply	70	FM IF COUNT	FM IF counter data input
32	SW2	CD mechanism switch 2 for 12cm disc	71		No use
33	CD LSI RESET	CD LSI reset	72		No use
34	MCLK	CD LSI command clock signal	73	Vdd	5V power supply
35	MDATA	CD LSI command data output	76	AM OSC	No use
36	MLD	CD LSI command load signal	75	FM OSC	FM input frequency
37		No use	76	Vss	Ground
38		No use	77		No use
39	SCL	E.volume clock output	78	EO	PLL error output signal
40	SDA	E.volume data output	79	TEST1	Connect to ground
			80	XOUT	4.5MHz crystal oscillation

■ HA13158A (IC321) : Power amp

1. Pin layout

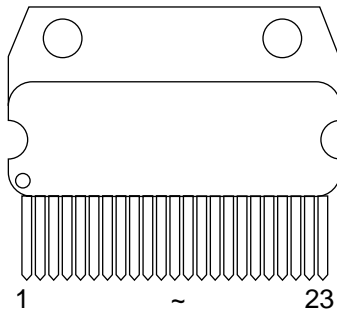

2. Block diagram

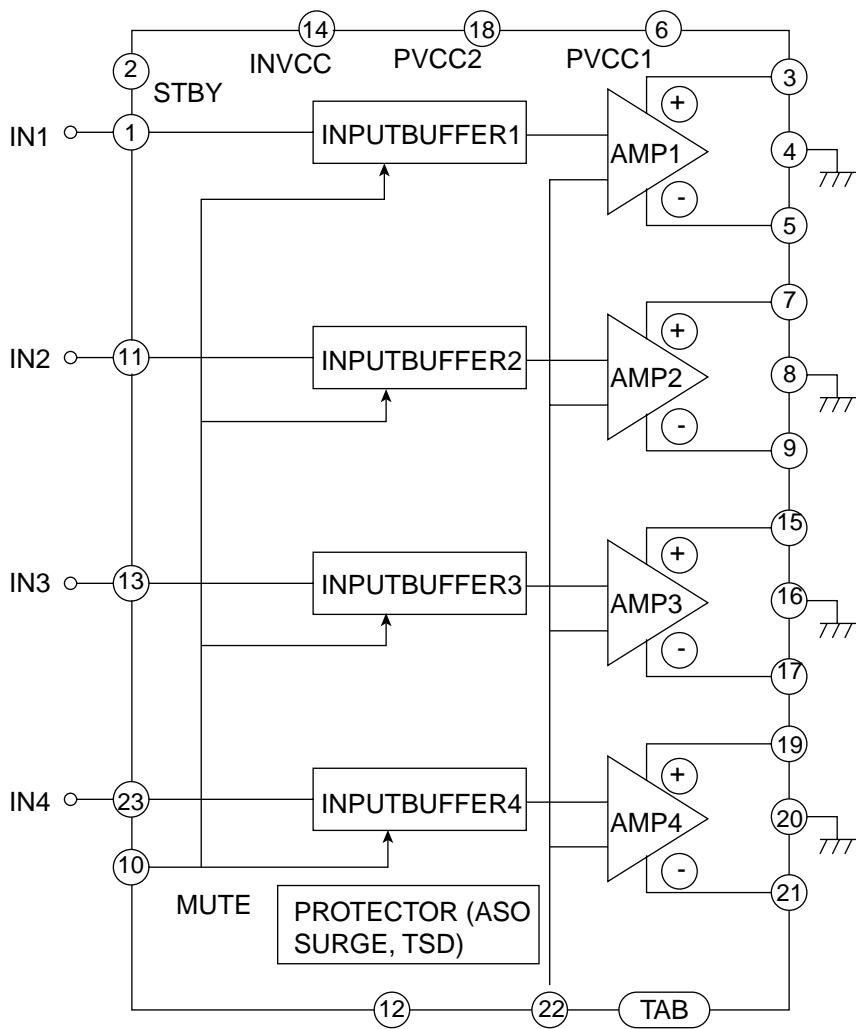

■ BA6218 (IC542) : Motor driver

1. Block diagram

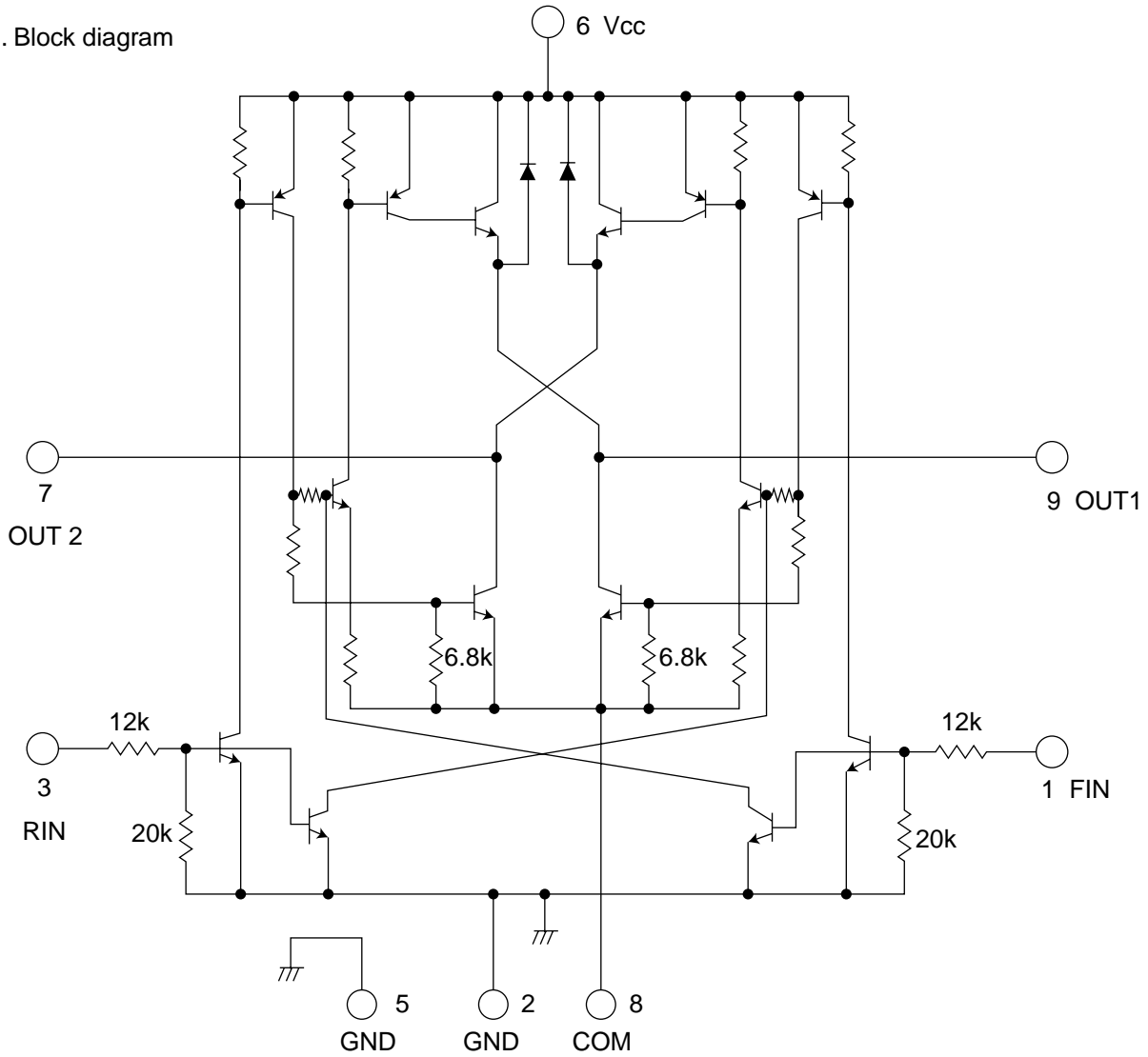

2. Function truth table

3Pin (IN)	1Pin (IN)	7Pin (OUT)	9Pin (OUT)
H	L	H	H
L	H	H	L
H	H	L	L
L	L	OPEN	OPEN

HA13164(IC901):REGULATOR

1.Terminal layout

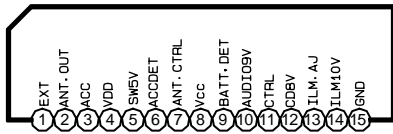

2.Block diagram

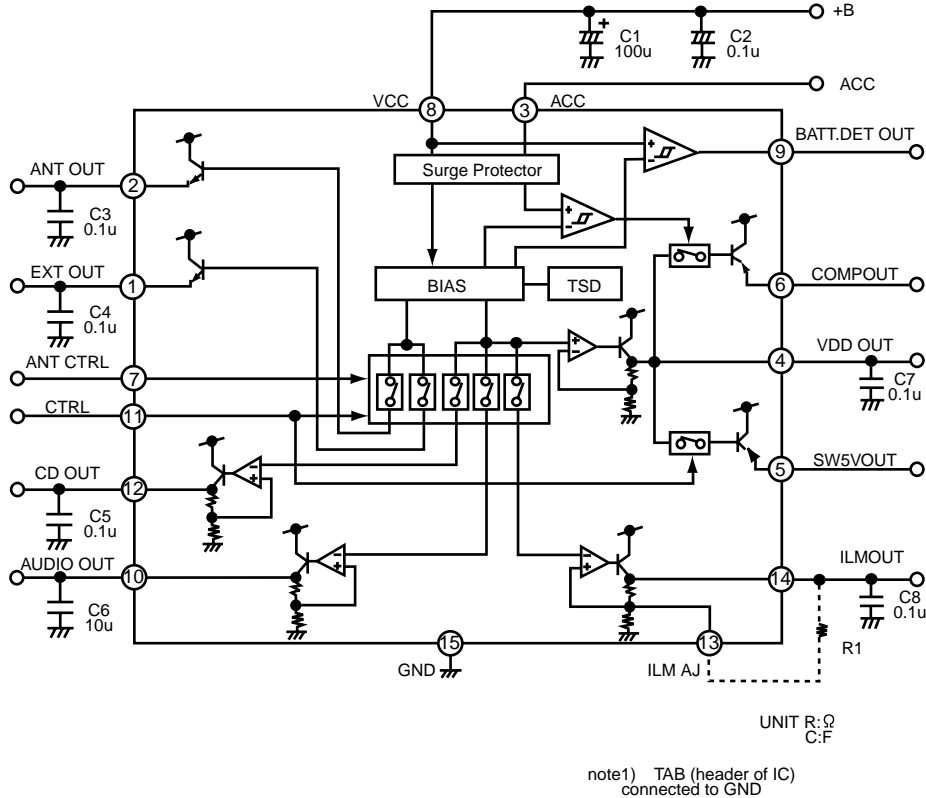

3.Pin function

Pin No.	Symbol	Function
1	EXTOUT	Output voltage is VCC-1 V when M or H level applied to CTRL pin.
2	ANTOUT	Output voltage is VCC-1 V when M or H level to CTRL pin and H level to ANT-CTRL.
3	ACCIN	Connected to ACC.
4	VDDOUT	Regular 5.7V.
5	SW5VOUT	Output voltage is 5V when M or H level applies to CTRL pin.
6	COMPOUT	Output for ACC detector.
7	ANT CTRL	L:ANT output OFF , H:ANT output ON
8	VCC	Connected to VCC.
9	BATT DET	Low battery detect.
10	AUDIO OUT	Output voltage is 9V when M or H level applied to CTRL pin.
11	CTRL	L:BIAS OFF, M:BIAS ON, H:CD ON
12	CD OUT	Output voltage is 8V when H level applied to CTRL pin.
13	ILM AJ	Adjustment pin for ILM output voltage.
14	ILM OUT	Output voltage is 10V when M or H level applies to CTRL pin.
15	GND	Connected to GND.

■ NJM4565M-WE (IC151) : Ope. amp

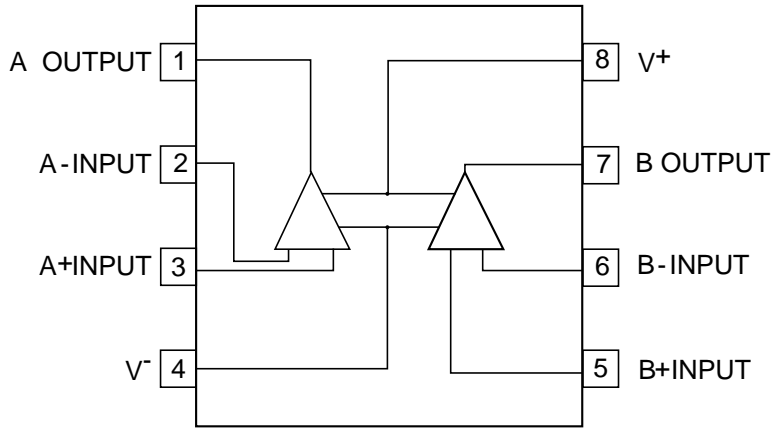

JVC

VICTOR COMPANY OF JAPAN, LIMITED
MOBILE ELECTRONICS DIVISION
PERSONAL & MOBILE NETWORK BUSINESS UNIT. 10-1,1Chome,Ohwatari-machi,Maebashi-city,Japan

Block diagram

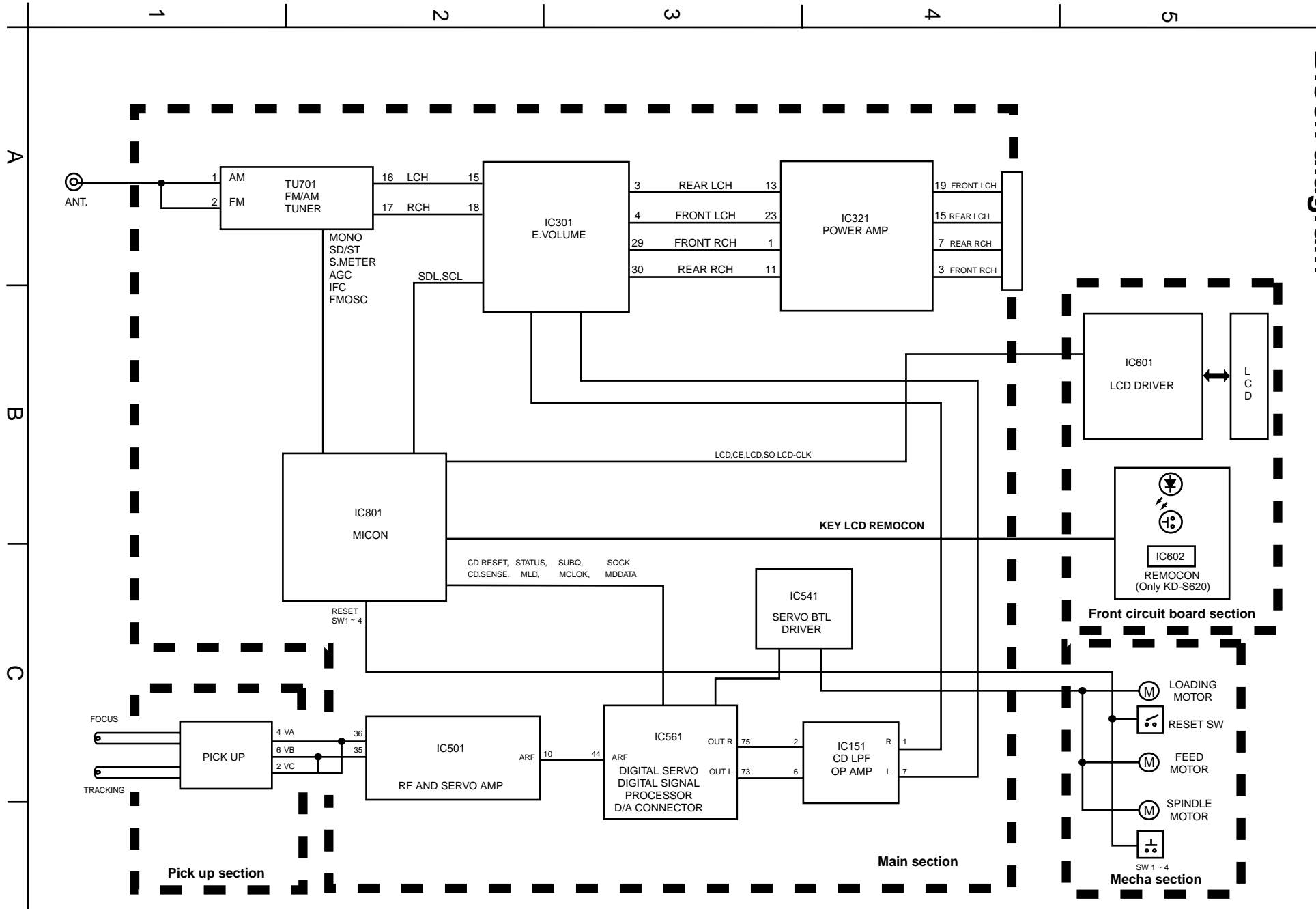

< MEMO >

Standard schematic diagrams

Main amp. section

5

4

3

2

1

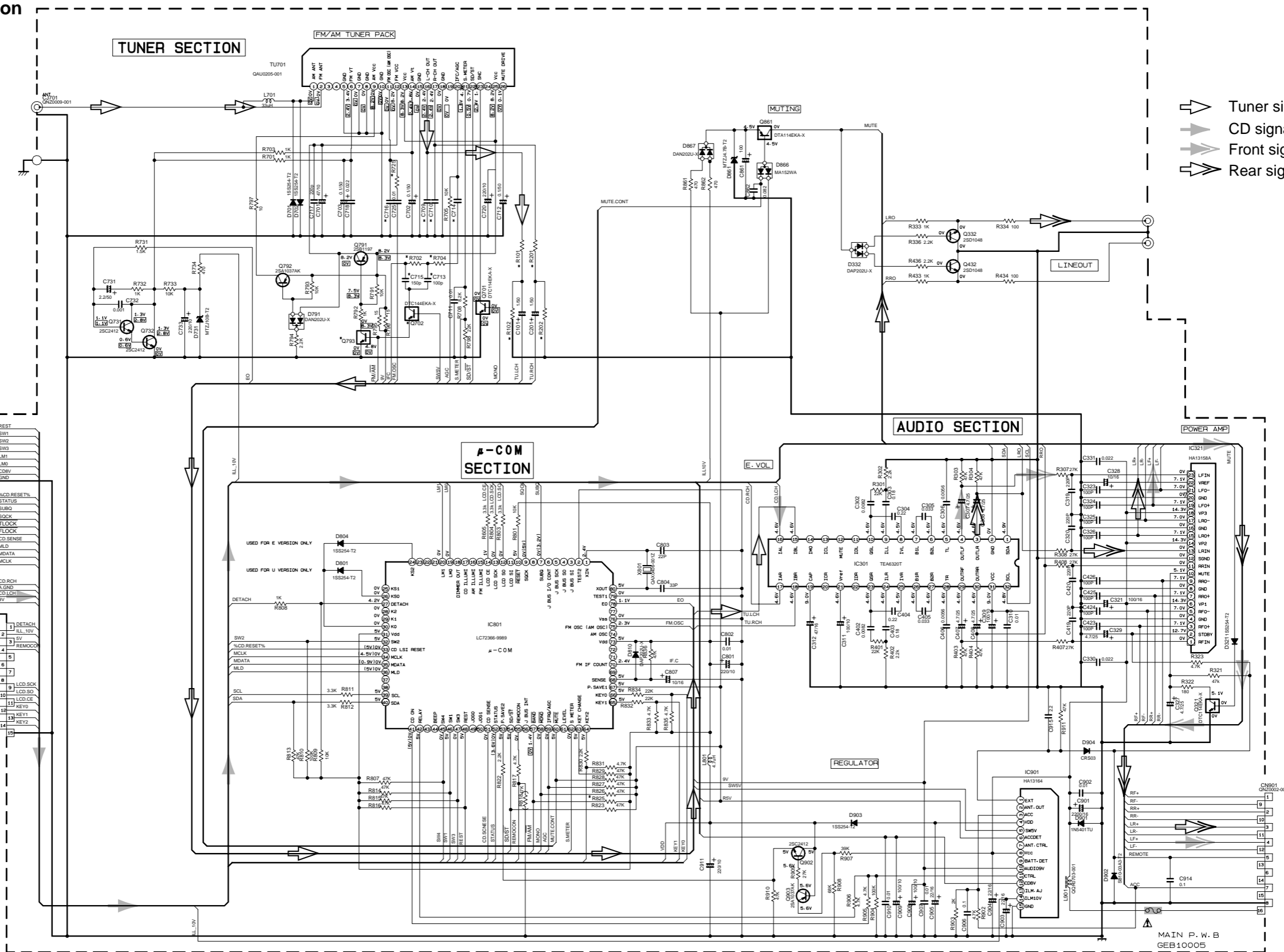

- Tuner signal
- CD signal
- Front signal
- Rear signal

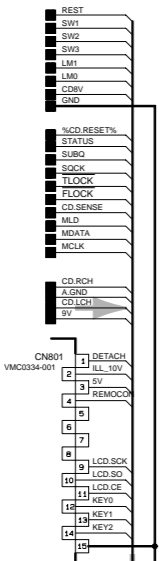

REMARK 1

Part No.	Value	U	E
C701-C715	100pF	100	100
R701-R715	10k	100	100
R716-R720	100k	100	100
R721-R725	1k	100	100
R726-R730	10k	100	100
R731-R735	100k	100	100
R736-R740	1k	100	100
R741-R745	10k	100	100
R746-R750	100k	100	100
R751-R755	1k	100	100
R756-R760	10k	100	100
R761-R765	100k	100	100
R766-R770	1k	100	100
R771-R775	10k	100	100
R776-R780	100k	100	100
R781-R785	1k	100	100
R786-R790	10k	100	100
R791-R795	100k	100	100
R796-R800	1k	100	100
R801-R805	10k	100	100
R806-R810	100k	100	100
R811-R815	1k	100	100
R816-R820	10k	100	100
R821-R825	100k	100	100
R826-R830	1k	100	100
R831-R835	10k	100	100
R836-R840	100k	100	100
R841-R845	1k	100	100
R846-R850	10k	100	100
R851-R855	100k	100	100
R856-R860	1k	100	100
R861-R865	10k	100	100
R866-R870	100k	100	100
R871-R875	1k	100	100
R876-R880	10k	100	100
R881-R885	100k	100	100
R886-R890	1k	100	100
R891-R895	10k	100	100
R896-R900	100k	100	100
R901-R905	1k	100	100
R906-R910	10k	100	100
R911-R915	100k	100	100
R916-R920	1k	100	100
R921-R925	10k	100	100
R926-R930	100k	100	100
R931-R935	1k	100	100
R936-R940	10k	100	100
R941-R945	100k	100	100
R946-R950	1k	100	100
R951-R955	10k	100	100
R956-R960	100k	100	100
R961-R965	1k	100	100
R966-R970	10k	100	100
R971-R975	100k	100	100
R976-R980	1k	100	100
R981-R985	10k	100	100
R986-R990	100k	100	100
R991-R995	1k	100	100
R996-R1000	10k	100	100

NOTES: VOLTAGE ARE DC-MEASURED WITH A DIGITAL VOLTMETER WITHOUT INPUT SIGNAL CONDITION
 →FM (CD AM MODE: 1 1 CD MODE)

Parts are safety assurance parts. When replacing those parts make sure to use the specified one.

Note: tr/s/3165xx/3165ma.001
 KD-S570J, KD-S575, KD-S620J, KD-S611Eseries
 FSDH3165-005TW 1/3

CD servo & control section

5

4

3

2

1

CD SECTION

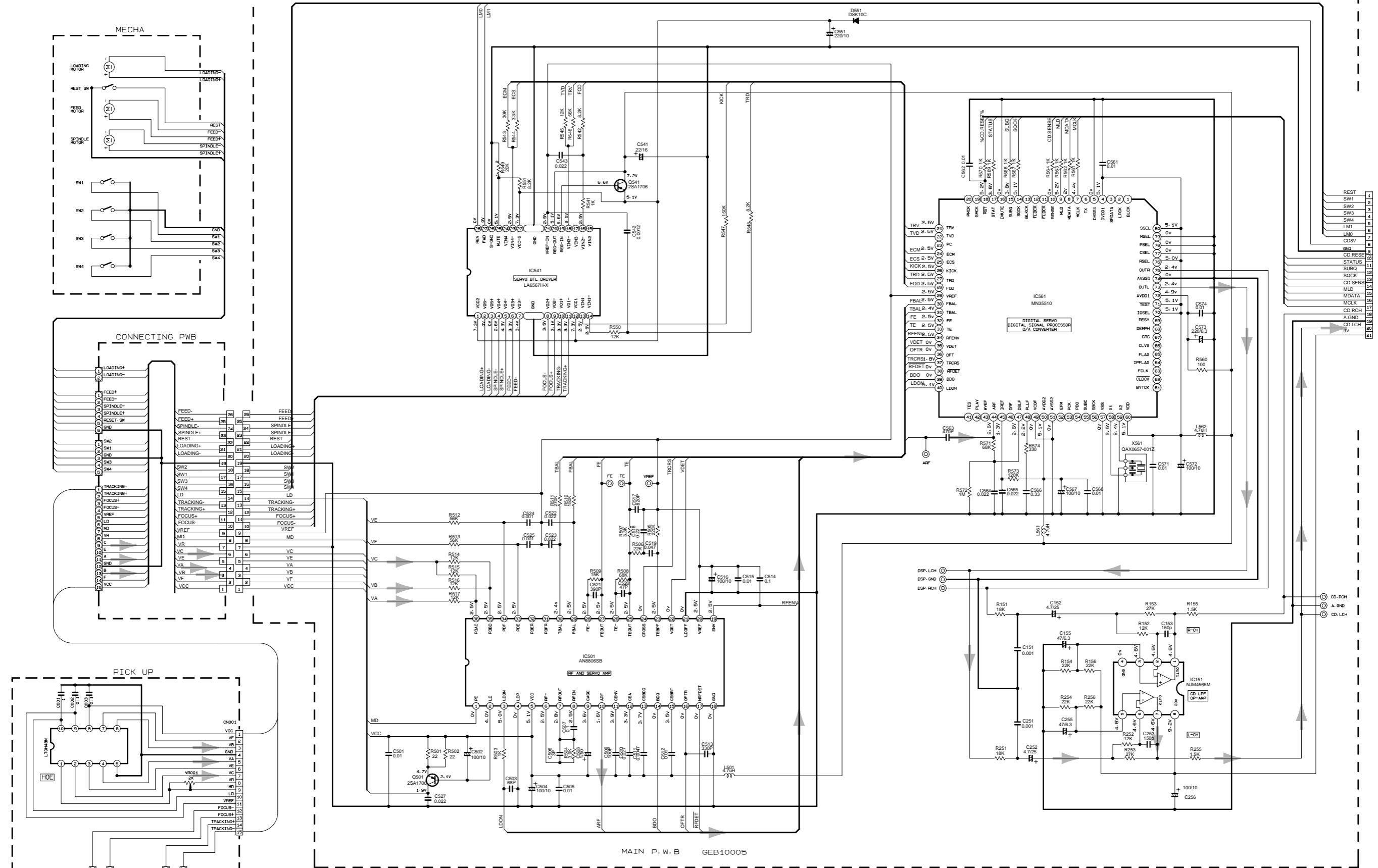

REST	1
SW1	2
SW2	3
SW3	4
SW4	5
LMD	6
CDV	7
CD RES	8
STATUS	9
SUBQ	10
SOCK	11
CD SENSE	12
MLD	13
MCLX	14
MCLK	15
CD RCH	16
CD LCH	17
A.GND	18
CD LCH	19
AV	20

NOTE : VOLTAGE ARE DC-MEASURED WITH DIGITAL VOLTMETER WITHOUT INPUT SIGNAL CONDITION
 --- CD MODE

➔ CD signal

■ LCD & key control section

5

4

3

2

1

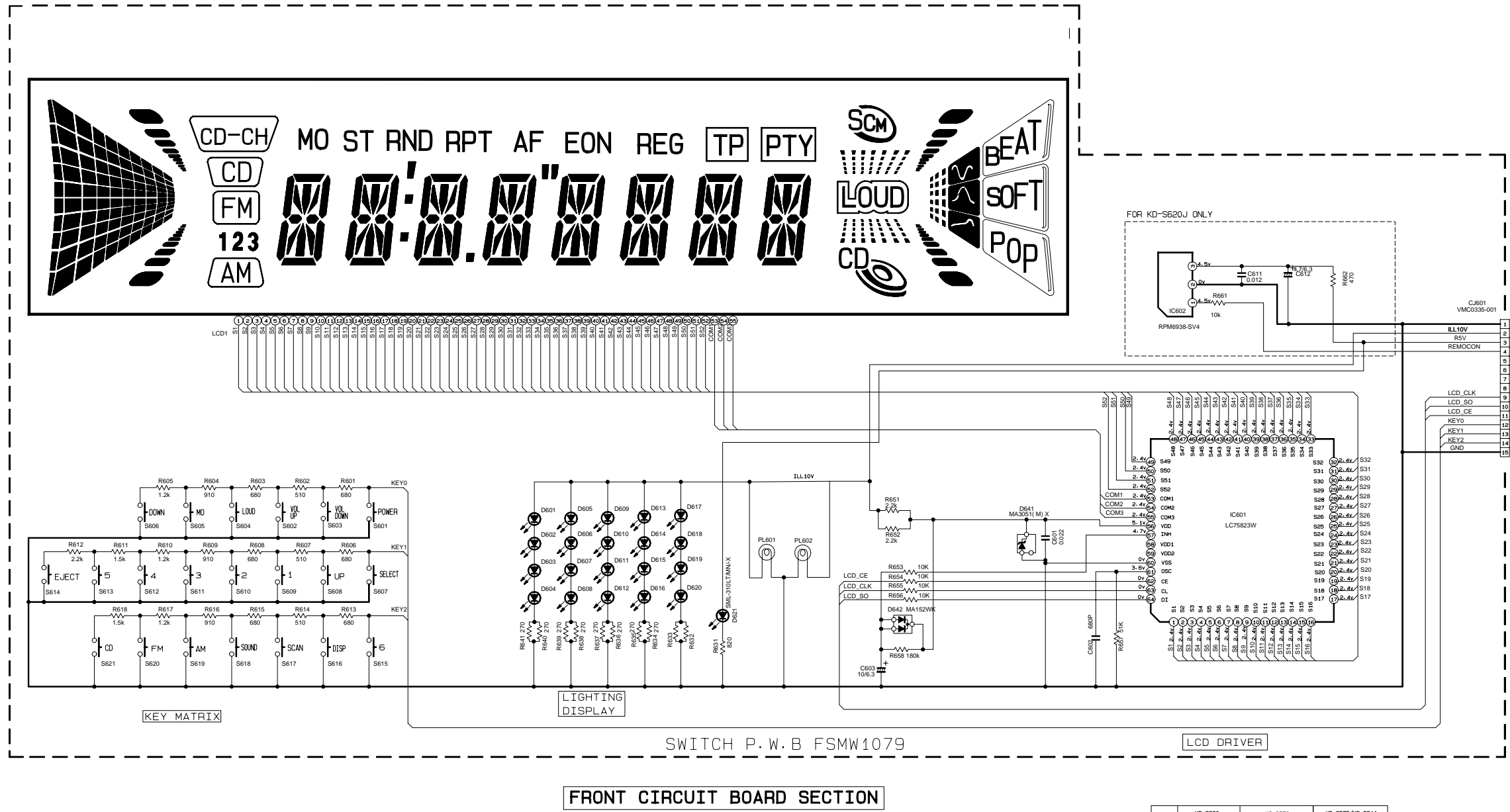

FRONT CIRCUIT BOARD SECTION

	KD-S620	KD-S670	KD-S675/KD-S611
PL601 PL602	QLL0033-003	QLL0033-003	QLL0056-001
D617 D618 D619	SM-310VT/JK/-X	LNJ308081/1-3/X	
R632 R633	NR8A02J-391X	NR8A02J-271X	
LCD1	QLD0161-001	QLD0161-001	
D601- D616	LNJ308081/1-3/X		
S601- S621	NSW0124-001X		

NOTE VOLTAGE ARE DC-MEASURED WITH DIGITAL VOLT-METER WITHOUT INPUT SIGNAL CONDITION

MODEL	SWITCH BOARD
KD-S570J	KD-SWPCB-1
KD-S620J	KD-SWPCB-2
KD-S575U Series/ KD-S611E Series	KD-SWPCB-8

Note: /tr/s/jes/3165xx/3165sw.001
KD-S570J, KD-S575U, KD-S620J, KD-S611E series
FSDH3165-005SW 3/3

Printed circuit boards

■ Main board

■ LCD & key control board

5
4
3
2
1

(Forward side)

(Reverse side)

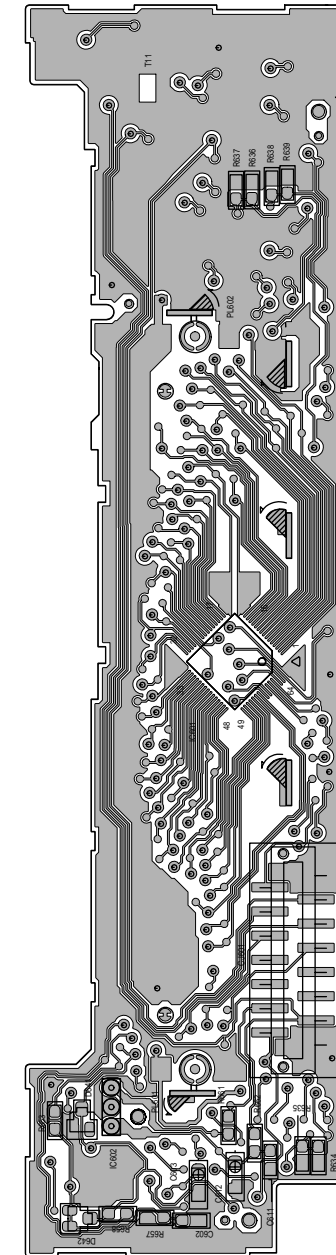
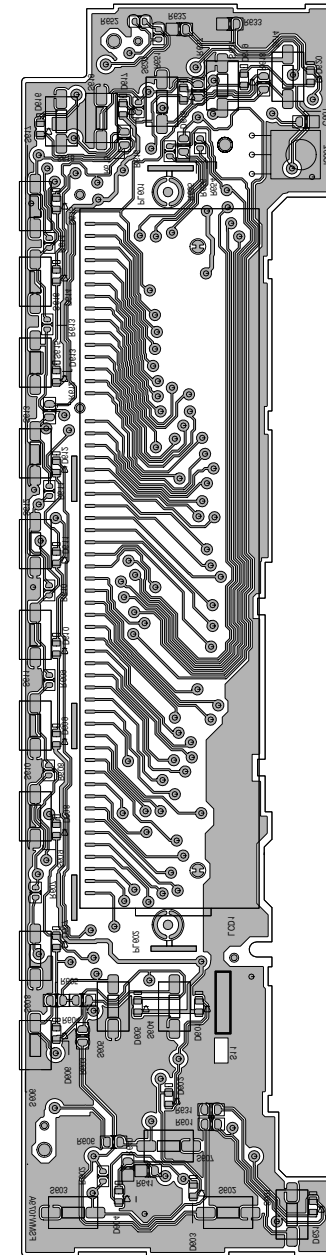
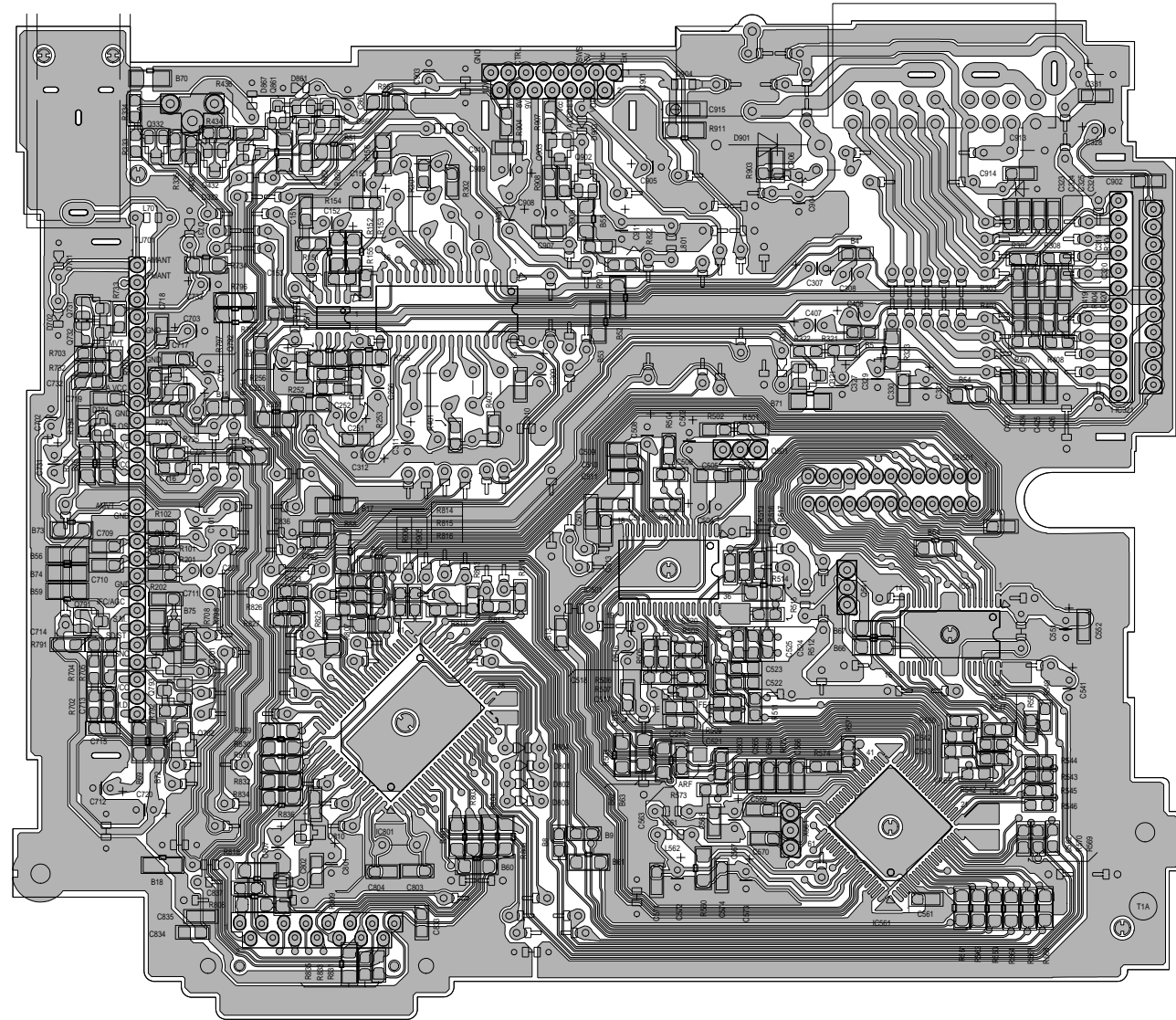

PARTS LIST

[KD-S611]

* All printed circuit boards and its assemblies are not available as service parts.

Area suffix
 E ----- Continental Europe

- Contents -

Exploded view of general assembly and parts list	3- 2
CD mechanism assembly and parts list	3- 4
Electrical parts list	3- 7
Packing materials and accessories parts list	3-12

Exploded view of general assembly and parts list

Block No. M 1 M M

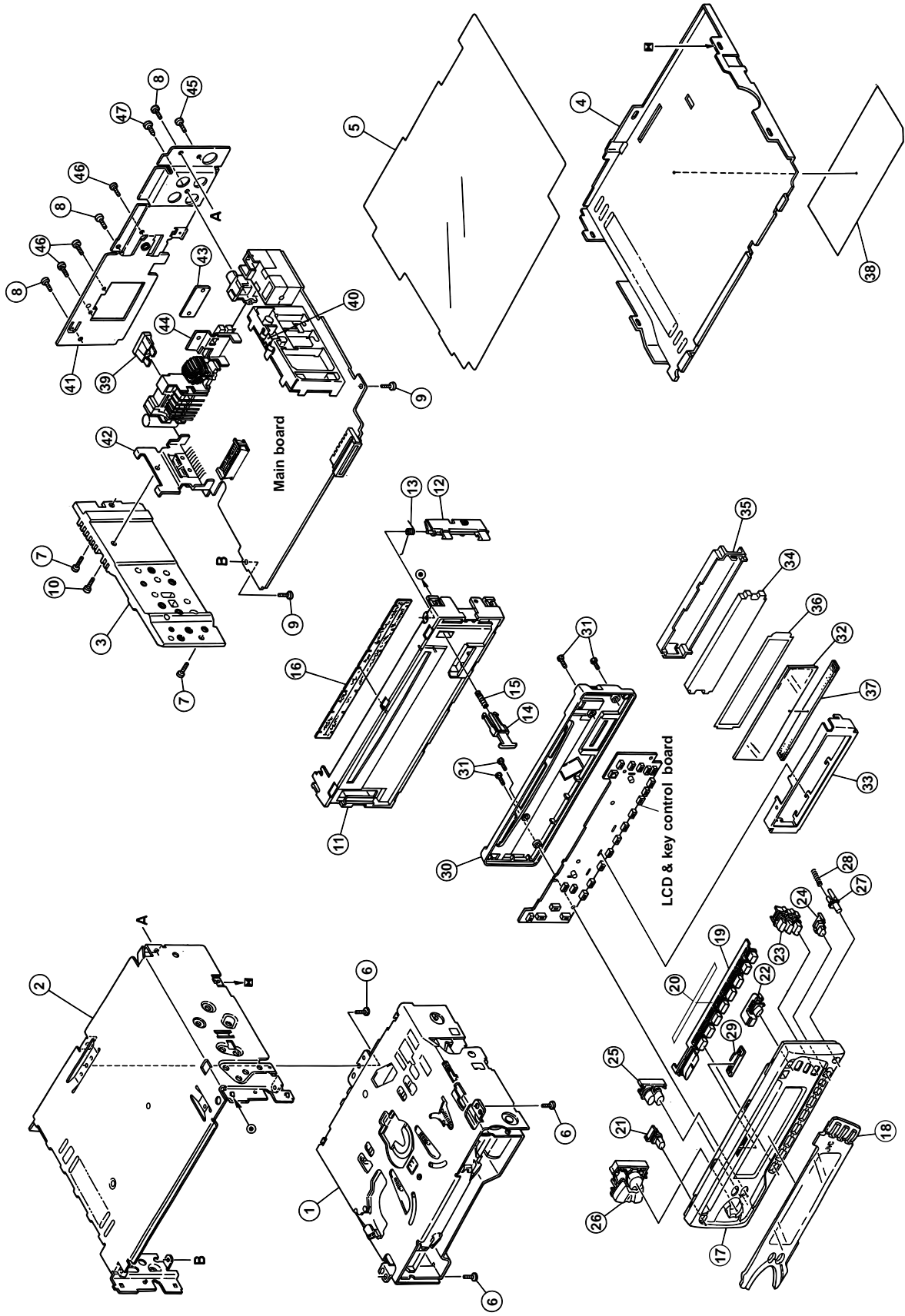

Parts list (General assembly)

Block No. M1MM

△	Item	Parts number	Parts name	Q'ty	Description	Area
	1	-----	CD MECHA	1	TN-CCD1001Z	
	2	FSJC1029-401	TOP CHASSIS	1		
	3	FSMH3001-202	SIDE PANEL	1		
	4	FSKM3011-002	BOTTOM COVER	1		
	5	FSMA3004-003	INSULATOR	1		
	6	QYSDST2604Z	SCREW	3	CHASSIS+MECHA BKT	
	7	FSKZ4005-001	SCREW	2	CHASSIS+SIDE PANEL	
	8	QYSDST2604Z	SCREW	3	CHASSIS+REAR BKT	
	9	QYSDST2606Z	SCREW	2	CHASSIS+MAIN PWB	
	10	FSKZ4005-001	SCREW	1	SIDE PANEL+IC BKT	
	11	FSJC2013-002	FRONT CHASSIS	1		
	12	FSKS3010-001	LOCK LEVER	1		
	13	FSKW4005-003	TORSION SPRING	1	FOR LOCK LEVER	
	14	FSXP3026-002	RLS KNOB	1		
	15	FSKW3002-015	COMP SPRING	1		
	16	FSPK3009-001	BLIND	1		
	17	FSJC1057-003	FRONT PANEL	1		
	18	FSJD3023-00J	FINDER ASSY	1		
	19	FSXP2035-108	PRESET BUTTON	1		
	20	FSYH4036-031	SHEET	1		
	21	FSXP3053-002	POWER BUTTON	1		
	22	FSXP3054-002	EJECT BUTTON	1		
	23	FSXP2034-034	D FUNC BUTTON	1	CD/FM/AM	
	24	FSXP4005-029	BBE BUTTON	1	SCM	
	25	FSXP3068-001	PUSH BUTTON	1		
	26	FSXP2044-001	COMBO BUTTON	1		
	27	FSXP3055-001	DETACH BUTTON	1		
	28	FSKW3002-012	COMP SPRING	1	FOR DETACH BUTTON	
	29	FSJK3026-001	CD LENS	1		
	30	FSJC1043-002	REAR COVER	1		
	31	VKZ4777-001	MINI SCREW	4	FRONT+REAR	
	32	QLD0161-001	LCD	1		
	33	FSYH3023-001	LCD CASE	1		
	34	FSJK3035-001	LCD LENS	1		
	35	FSKS3022-002	LENS CASE	1		
	36	FSYH4078-001	LIGHTING SHEET	1		
	37	QNZ0442-001	RUBBER CONNE	1		
	38	GE30133-002A	NAME PLATE	1		
△	39	QMFZ021-100-J1	FUSE	1		
	40	VMA4652-001SS	EARTH PLATE	1		
	41	FSKM3010-013	REAR BRACKET	1		
	42	FSKL4018-00B	IC BRACKET	1		
	43	GE40104-002B	HEAT SINK	1		
	44	GE40103-001A	REGULATOR BKT	1		
	45	QYSDST2606Z	SCREW	1	FOR ANT	
	46	QYSDST2606Z	SCREW	3	16P & TR BRACK	
	47	QYSDSF3006Z	SCREW	1	LINE OUT	

CD mechanism assembly and parts list

Block No. M 2 M M

Grease

- ★ G-31SA
- ※ G-31SA(Bottom side)
- RX-405

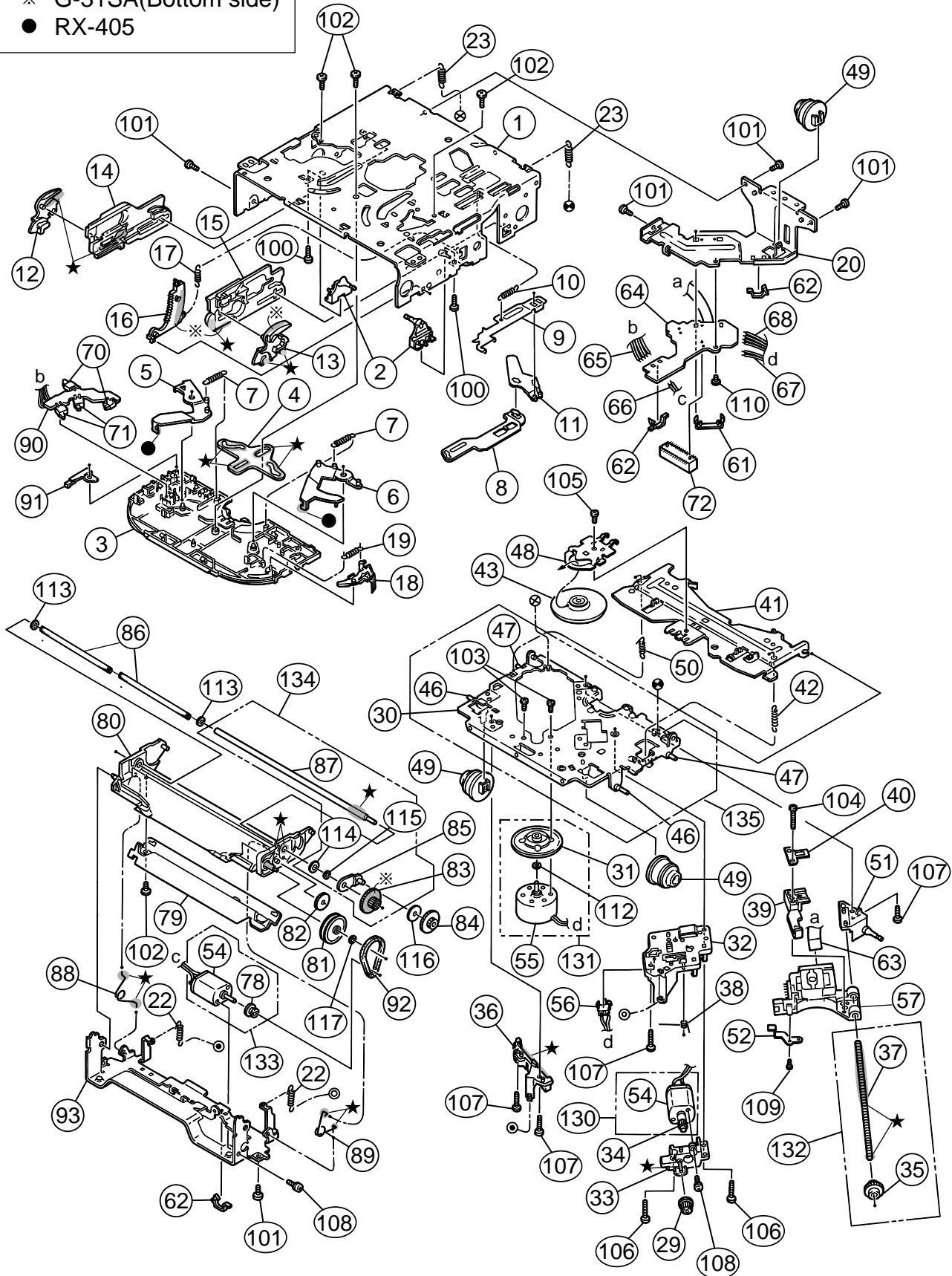

Parts list (CD mechanism)

Block No. M2MM

△	Item	Parts number	Parts name	Q'ty	Description	Area
	1	30310101T	FRAME	1		
	2	30310103T	DANPER PIN	2		
	3	30310107T	UPPER PLATE	1		
	4	30310108T	SEL STOP PLATE	1		
	5	30310142T	SEL ARM (L)L	1		
	6	30310143T	SEL ARM (R)L	1		
	7	30310145T	S ARM SPRING(L)	2		
	8	30310112T	TRIG LEVER	1		
	9	30310155T	TRIG PL(Z)	1		
	10	30310115T	TRIG PL SPRING	1		
	11	30310116T	TRIG ARM	1		
	12	30310134T	FIX ARM (L)B	1		
	13	30310159T	FIX ARM (R)Z	1		
	14	30310150T	FIX PL (L)Z	1		
	15	30310156T	FIX PL (R) Z	1		
	16	30310138T	LDG GR (6)B	1		
	17	30310122T	LDG GEAR (6)SP	1		
	18	30310148T	S.L ARM(N)	1		
	19	30310125T	S.L ARM SPRING	1		
	20	30310149T	REAR DAM BKT(Z)	1		
	22	30310151T	HUNG UP SP (FZ)	2		
	23	30310129T	HUNG UP SP (R)	2		
	29	30300510T	PU GEAR(B)	1		
	30	-----	T.T.BASE(Z)	1		
	31	-----	TURN TABLE(Z)	1		
	32	30310544T	F.M.BASE(Z)	1		
	33	30310547T	FD GR BLK(Z)	1		
	34	-----	FD GR AZ	1		
	35	-----	FD GR CZ	1		
	36	30310546T	PU GUIDE(Z)	1		
	37	-----	FD SCREW(Z)	1		
	38	30310533T	THRUST SPR(M)	1		
	39	30310548T	PU M NUT(Z)	1		
	40	30310512T	NUT PUSH SPR PL	1		
	41	30310558T	CLP ARM(Z)	1		
	42	30310514T	CLP ARM SPRING	1		
	43	30310552T	CLAMPER(Z)	1		
	46	-----	LOCK PIN(FZ)	2		
	47	-----	LOCK PIN(RZ)	2		
	48	30310557T	CLAMPER PLATE(Z)	1		
	49	30310524T	DAMPER (J)	3		
	50	30310525T	CLP ARM SPR (L)	1		
	51	30310545T	F SCREW GUIDE(Z)	1		
	52	30310556T	PU G.SP PLT(Z)	1		
	54	-----	FEED MOTOR	2	FF030PK-09210	
	55	-----	SPINDLE MOTOR	1	RF300CA-11440D	
	56	64180405T	DET SW	1	ESE11SF4	
	57	OPTIMA-720L1	C.D PICK (CAR)	1		

■ Parts list (CD mechanism)

Block No. M2MM

△	Item	Parts number	Parts name	Q'ty	Description	Area
	61	30311035T	FPC HOLDER(Z)	1		
	62	19501403T	WIRE CLAMPER	3		
	63	30311037T	PICK UP FPC(Z)	1		
	64	30311036T	CONNECT.PCB(Z-J)	1		
	65	30311038T	WIRE (5P-Z)	1		
	66	30311039T	WIRE (LD-Z)	1		
	67	30311040T	WIRE (FD-Z)	1		
	68	30311041T	WIRE (RS-Z)	1		
	70	64180402T	DET SWITCH	2	ESE22MH1	
	71	64180403T	DET SWITCH	2	ESE22MH3	
	72	68150232T	CONNECTOR	1	TKC-W26X-C1	
	78	-----	LDG PULLEY	1		
	79	30311105T	SOPPORT PLATE	1		
	80	30311138T	GR MT BLK(N)	1		
	81	30311109T	LDG GEAR (2)	1		
	82	30311110T	LDG GEAR (3)	1		
	83	-----	LDG GEAR (4)	1		
	84	30311112T	LDG GEAR (5)	1		
	85	-----	LDG GR ARM	1		
	86	30311136T	LDG ROLLER	2		
	87	-----	LDG RLR SHAFT	1		
	88	30311118T	L.P SPRING (L)	1		
	89	30311119T	L.P SPRING (R)	1		
	90	30311123T	SW PCB	1		
	91	30311124T	SW ACTUATOR	1		
	92	30311129T	LDG BELT	1		
	93	30311140T	FRONT BRKT (J)	1		
	100	9C0620503T	C B TAP SCREW	2	M2X5	
	101	9C2020401T	C SCREW TS.G	5	M2X4	
	102	9C4320403T	C B TAP SCREW	4	M2X4	
	103	9C0117223T	SCREW	2	M1.7X2.2	
	104	9C4217703T	C TAP SCREW S3	1	M1.7X7	
	105	9C0320201T	C TAP SCREW S3	1	M2X2	
	106	9C4920013T	C TAP SCREW S3	2	M2X10	
	107	9C4920603T	C TAP SCREW B3	4	M2X6	
	108	9P0220031T	TAMS SCREW	2	M2X3	
	109	9C0314203T	C TAP SCREW	1	M1.4X2	
	110	9C0420253	C TAP SCREW	1	M2X2.5	
	112	-----	POLY WASHER	1	2.1X3.5X0.3	
	113	9W0330276	NW BLUE	2	2.9X5X0.3	
	114	-----	WAVE WASHER	1		
	115	-----	LUMILAR WASHER	1	2.5X6X0.1	
	116	9W0725030T	LUMILAR WASHER	1	2.3X9.8X0.25	
	117	9W0640030T	WASHER	1	1.4X3.2X0.4	
	130	303105310T	FEED MO ASSY	1	NO.34 54	
	131	303105311T	SPINDLE MO ASSY	1	NO.31 55 112	
	132	303105312T	FEED SCREW ASSY	1	NO.35 37	
	133	303111301T	LDG MOTOR ASSY	1	NO.54 78	
	134	303111302T	ROLLER SHAFT	1	NO.83 85 87	
		303111302T	ROLLER SHAFT	1	NO.114 115	
	135	303105502T	T.T.BASE ASSY	1	NO.30 46 47	

■ Electrical parts list (Main board)

Block No. 01

△	Item	Parts number	Parts name	Remarks	Area	△	Item	Parts number	Parts name	Remarks	Area
	C 101	QERF1HM-105Z	E CAPACITOR	1.0MF 20% 50V			C 517	NCS31HJ-821X	C CAPACITOR		
	C 151	NCB31HK-102X	C CAPACITOR				C 518	NCB31AK-224X	C CAPACITOR		
	C 152	QEKJ1EM-475Z	E CAPACITOR	4.7MF 20% 25V			C 519	NCB31EK-473X	C CAPACITOR		
	C 153	NCS31HJ-151X	C CAPACITOR				C 520	NDC31HJ-470X	C CAPACITOR		
	C 155	QEKJ0JM-476Z	E CAPACITOR	47MF 20% 6.3V			C 521	NCS31HJ-391X	C CAPACITOR		
	C 201	QERF1HM-105Z	E CAPACITOR	1.0MF 20% 50V			C 522	NCB31HK-223X	C CAPACITOR		
	C 251	NCB31HK-102X	C CAPACITOR				C 523	NCB31HK-223X	C CAPACITOR		
	C 252	QEKJ1EM-475Z	E CAPACITOR	4.7MF 20% 25V			C 524	NCB31HK-102X	C CAPACITOR		
	C 253	NCS31HJ-151X	C CAPACITOR				C 525	NCB31HK-102X	C CAPACITOR		
	C 255	QEKJ0JM-476Z	E CAPACITOR	47MF 20% 6.3V			C 527	NCB31EK-223X	C CAPACITOR		
	C 256	QEKJ1AM-107Z	E CAPACITOR	100MF 20% 10V			C 541	QERF1CM-226Z	E CAPACITOR	22MF 20% 16V	
	C 302	QFLA1HJ-822Z	M CAPACITOR	8200PF 5% 50V			C 542	NCB31HK-122X	C CAPACITOR		
	C 303	QFV61HJ-184Z	MF CAPACITOR	.18MF 5% 50V			C 543	NCB31EK-223X	C CAPACITOR		
	C 304	QFV61HJ-224Z	MF CAPACITOR	.22MF 5% 50V			C 551	QERF1AM-227Z	E CAPACITOR	220MF 20% 10V	
	C 305	QFV61HJ-333Z	MF CAPACITOR	.033MF 5% 50V			C 561	NCB31EK-103X	C CAPACITOR		
	C 306	QFLA1HJ-562Z	M CAPACITOR	5600PF 5% 50V			C 562	NCB31EK-103X	C CAPACITOR		
	C 307	QERF1EM-475Z	E CAPACITOR	4.7MF 20% 25V			C 563	NCB31HK-471X	C CAPACITOR		
	C 308	QERF1EM-475Z	E CAPACITOR	4.7MF 20% 25V			C 564	NCB31HK-223X	C CAPACITOR		
	C 309	QEKJ1AM-107Z	E CAPACITOR	100MF 20% 10V			C 565	NCB31HK-223X	C CAPACITOR		
	C 310	NCB31HK-103X	C CAPACITOR				C 566	NCB31AK-334X	C CAPACITOR		
	C 311	QEKJ1AM-107Z	E CAPACITOR	100MF 20% 10V			C 567	QEKJ1AM-107Z	E CAPACITOR	100MF 20% 10V	
	C 312	QEKJ1CM-476Z	E CAPACITOR	47MF 20% 16V			C 568	NCB31EK-103X	C CAPACITOR		
	C 319	NCS31HJ-221X	C CAPACITOR				C 571	NCB31EK-103X	C CAPACITOR		
	C 320	NCS31HJ-221X	C CAPACITOR				C 572	QEKJ1AM-107Z	E CAPACITOR	100MF 20% 10V	
	C 321	QERF1CM-107Z	E CAPACITOR	100MF 20% 16V			C 573	QEKJ0JM-227Z	E CAPACITOR	220MF 20% 6.3V	
	C 323	NCS31HJ-101X	C CAPACITOR				C 574	NCB31EK-103X	C CAPACITOR		
	C 324	NCS31HJ-101X	C CAPACITOR				C 701	QERF1AM-476Z	E CAPACITOR	47MF 20% 10V	
	C 325	NCS31HJ-101X	C CAPACITOR				C 702	QEKJ1HM-104Z	E CAPACITOR	.10MF 20% 50V	
	C 326	NCS31HJ-101X	C CAPACITOR				C 703	QEKJ1HM-104Z	E CAPACITOR	.10MF 20% 50V	
	C 327	QEKJ1EM-475Z	E CAPACITOR	4.7MF 20% 25V			C 709	NCB31HK-223X	C CAPACITOR		
	C 328	QEKJ1CM-106Z	E CAPACITOR	10MF 20% 16V			C 710	NCB31HK-223X	C CAPACITOR		
	C 329	QERF1EM-475Z	E CAPACITOR	4.7MF 20% 25V			C 711	NCB31EK-103X	C CAPACITOR		
	C 330	NCB31HK-223X	C CAPACITOR				C 712	QEKJ1HM-104Z	E CAPACITOR	.10MF 20% 50V	
	C 331	NCB31HK-223X	C CAPACITOR				C 713	NCS31HJ-101X	C CAPACITOR		
	C 402	QFLA1HJ-822Z	M CAPACITOR	8200PF 5% 50V			C 714	NCB31HK-103X	C CAPACITOR		
	C 403	QFV61HJ-184Z	MF CAPACITOR	.18MF 5% 50V			C 715	NCS31HJ-151X	C CAPACITOR		
	C 404	QFV61HJ-224Z	MF CAPACITOR	.22MF 5% 50V			C 717	NCS31HJ-221X	C CAPACITOR		
	C 405	QFV61HJ-333Z	MF CAPACITOR	.033MF 5% 50V			C 718	NCB31HK-223X	C CAPACITOR		
	C 406	QFLA1HJ-562Z	M CAPACITOR	5600PF 5% 50V			C 720	QERF1AM-227Z	E CAPACITOR	220MF 20% 10V	
	C 407	QERF1EM-475Z	E CAPACITOR	4.7MF 20% 25V			C 725	NCB31EK-103X	C CAPACITOR		
	C 408	QERF1EM-475Z	E CAPACITOR	4.7MF 20% 25V			C 731	QERF1HM-225Z	E CAPACITOR	2.2MF 20% 50V	
	C 419	NCS31HJ-221X	C CAPACITOR				C 732	NCB31HK-102X	C CAPACITOR		
	C 420	NCS31HJ-221X	C CAPACITOR				C 733	QERF1AM-227Z	E CAPACITOR	220MF 20% 10V	
	C 423	NCS31HJ-101X	C CAPACITOR				C 801	QERF1AM-227Z	E CAPACITOR	220MF 20% 10V	
	C 424	NCS31HJ-101X	C CAPACITOR				C 802	NCB31EK-103X	C CAPACITOR		
	C 425	NCS31HJ-101X	C CAPACITOR				C 803	NDC31HJ-220X	C CAPACITOR		
	C 426	NCS31HJ-101X	C CAPACITOR				C 804	NDC31HJ-330X	C CAPACITOR		
	C 501	NCB31EK-103X	C CAPACITOR				C 807	QERF1CM-106Z	E CAPACITOR	10MF 20% 16V	
	C 502	QEKJ1AM-107Z	E CAPACITOR	100MF 20% 10V			C 861	QEKJ0JM-227Z	E CAPACITOR	220MF 20% 6.3V	
	C 503	NCS31HJ-680X	C CAPACITOR				C 862	NCB31EK-823X	C CAPACITOR		
	C 504	QEKJ1AM-107Z	E CAPACITOR	100MF 20% 10V			C 901	QEZ0518-228	E CAPACITOR	2200MF	
	C 505	NCB31EK-103X	C CAPACITOR				C 902	NCB31HK-103X	C CAPACITOR		
	C 506	NDC31HJ-3R0X	C CAPACITOR				C 903	QEKJ1CM-226Z	E CAPACITOR	22MF 20% 16V	
	C 507	NCB31EK-104X	C CAPACITOR				C 904	QERF1CM-226Z	E CAPACITOR	22MF 20% 16V	
	C 508	QEKJ1HM-105Z	E CAPACITOR	1.0MF 20% 50V			C 905	QERF1CM-226Z	E CAPACITOR	22MF 20% 16V	
	C 509	NDC31HJ-101X	C CAPACITOR				C 906	NCB31EK-104X	C CAPACITOR		
	C 510	NCB31EK-273X	C CAPACITOR				C 907	NCB31HK-103X	C CAPACITOR		
	C 511	NCB31HK-472X	C CAPACITOR				C 908	QERF1AM-107Z	E CAPACITOR	100MF 20% 10V	
	C 512	NCB31HK-103X	C CAPACITOR				C 909	QERF1AM-107Z	E CAPACITOR	100MF 20% 10V	
	C 513	NDC31HJ-331X	C CAPACITOR				C 910	NCB31HK-103X	C CAPACITOR		
	C 514	NCB31EK-104X	C CAPACITOR				C 911	QERF1AM-227Z	E CAPACITOR	220MF 20% 10V	
	C 515	NCB31EK-103X	C CAPACITOR				C 914	NCB31EK-104X	C CAPACITOR		
	C 516	QEKJ1AM-107Z	E CAPACITOR	100MF 20% 10V			C 915	NCB11CK-225X	C CAPACITOR		

■ Electrical parts list (Main board)

Block No. 01

△	Item	Parts number	Parts name	Remarks	Area	△	Item	Parts number	Parts name	Remarks	Area
	CJ321	QNN0170-001	PIN JACK (REEL)				R 254	NRSA63J-223X	MG RESISTOR		
	CJ701	QNB0100-001	ANTENNA JACK				R 255	NRS181J-152X	MG RESISTOR		
	CN501	QGB2027M1-26S	CONNECTOR				R 256	NRS181J-223X	MG RESISTOR		
	CN801	VMC0334-001	CONNECTOR				R 301	NRSA63J-223X	MG RESISTOR		
	CN901	QNZ0002-001	16P CONNECTOR				R 302	NRSA63J-222X	MG RESISTOR		
	D 321	1SS254-T2	SI DIODE				R 303	NRSA63J-473X	MG RESISTOR		
	D 332	MA142WA-X	DIODE				R 304	NRSA63J-473X	MG RESISTOR		
	D 551	DSK10C-T1	DIODE				R 307	NRSA63J-273X	MG RESISTOR		
	D 701	1SS254-T2	SI DIODE				R 308	NRSA63J-273X	MG RESISTOR		
	D 702	1SS254-T2	SI DIODE				R 321	NRSA63J-473X	MG RESISTOR		
	D 731	MTZJ10B-T2	ZENER DIODE				R 322	NRSA63J-181X	MG RESISTOR		
	D 791	MA142WK-X	DIODE				R 323	NRS181J-472X	MG RESISTOR		
	D 804	1SS254-T2	SI DIODE				R 333	NRSA63J-102X	MG RESISTOR		
	D 810	MA142WK-X	DIODE				R 334	NRSA63J-101X	MG RESISTOR		
	D 861	MTZJ4.7B-T2	Z DIODE				R 336	NRSA63J-222X	MG RESISTOR		
	D 866	MA152WA-X	DIODE				R 401	NRSA63J-223X	MG RESISTOR		
	D 867	MA142WK-X	DIODE				R 402	NRSA63J-222X	MG RESISTOR		
	D 901	1N5401-TU-15	DIODE				R 403	NRSA63J-473X	MG RESISTOR		
	D 902	SB10-03A3-T2	SB DIODE				R 404	NRSA63J-473X	MG RESISTOR		
	D 903	1SS254-T2	SI DIODE				R 407	NRSA63J-273X	MG RESISTOR		
	D 904	CRS03-W	SB DIODE				R 408	NRSA63J-273X	MG RESISTOR		
	IC151	NJM4565M-WE	IC				R 433	NRSA63J-102X	MG RESISTOR		
	IC301	TEA6320T-X	IC				R 434	NRSA63J-101X	MG RESISTOR		
	IC321	HA13158A	IC				R 436	NRSA63J-222X	MG RESISTOR		
	IC501	AN8806SB-W	IC				R 501	NRSA63J-220X	MG RESISTOR		
	IC541	LA6567H-X	IC				R 502	NRSA63J-220X	MG RESISTOR		
	IC561	MN35510	IC				R 503	NRS181J-102X	MG RESISTOR		
	IC801	LC72366-9989	IC				R 504	NRSA63J-392X	MG RESISTOR		
	IC901	HA13164	IC				R 505	NRSA63J-224X	MG RESISTOR		
	L 501	QQL231K-4R7Y	INDUCTOR				R 506	NRSA63J-223X	MG RESISTOR		
	L 561	QQL231K-4R7Y	INDUCTOR				R 507	NRSA63J-332X	MG RESISTOR		
	L 562	QQL231K-4R7Y	INDUCTOR				R 508	NRSA63J-683X	MG RESISTOR		
	L 701	QQL231K-330Y	INDUCTOR				R 509	NRSA63J-153X	MG RESISTOR		
	L 801	QQL231K-4R7Y	INDUCTOR				R 510	NRSA63J-154X	MG RESISTOR		
	L 901	QQR0703-001	CHOKO COIL				R 511	NRSA63J-274X	MG RESISTOR		
	Q 321	DTC114EKA-X	TRANSISTOR				R 512	NRSA63J-563X	MG RESISTOR		
	Q 332	2SD1781K/QR/-X	TRANSISTOR				R 513	NRSA63J-563X	MG RESISTOR		
	Q 432	2SD1781K/QR/-X	TRANSISTOR				R 514	NRS181J-123X	MG RESISTOR		
	Q 501	2SA1706/ST/-T	TRANSISTOR				R 515	NRSA63J-123X	MG RESISTOR		
	Q 541	2SA1706/ST/-T	TRANSISTOR				R 516	NRSA63J-123X	MG RESISTOR		
	Q 701	DTC114EKA-X	TRANSISTOR				R 517	NRSA63J-123X	MG RESISTOR		
	Q 702	DTC144EKA-X	TRANSISTOR				R 541	NRSA63J-102X	MG RESISTOR		
	Q 731	2SC2412K/R/-X	TRANSISTOR				R 542	NRSA63J-822X	MG RESISTOR		
	Q 732	2SC2412K/R/-X	TRANSISTOR				R 543	NRSA63J-303X	MG RESISTOR		
	Q 791	2SB1197K/QR/-X	TRANSISTOR				R 544	NRSA63J-332X	MG RESISTOR		
	Q 792	2SA1037AK/RS/-X	TRANSISTOR				R 545	NRSA63J-123X	MG RESISTOR		
	Q 793	DTC114EKA-X	TRANSISTOR				R 546	NRSA63J-563X	MG RESISTOR		
	Q 861	DTA114EKA-X	DIGITAL TRANSIS				R 547	NRSA63J-154X	MG RESISTOR		
	Q 902	2SC2412K/R/-X	TRANSISTOR				R 548	NRSA63J-822X	MG RESISTOR		
	Q 903	2SA1037AK/RS/-X	TRANSISTOR				R 549	NRSA63J-203X	MG RESISTOR		
	R 101	NRSA63J-471X	MG RESISTOR				R 550	NRSA63J-123X	MG RESISTOR		
	R 102	NRSA63J-752X	MG RESISTOR				R 551	NRSA63J-822X	MG RESISTOR		
	R 151	NRSA63J-183X	MG RESISTOR				R 560	NRS181J-101X	MG RESISTOR		
	R 152	NRS181J-123X	MG RESISTOR				R 561	NRS181J-102X	MG RESISTOR		
	R 153	NRS181J-273X	MG RESISTOR				R 562	NRS181J-102X	MG RESISTOR		
	R 154	NRSA63J-223X	MG RESISTOR				R 563	NRS181J-102X	MG RESISTOR		
	R 155	NRSA63J-152X	MG RESISTOR				R 564	NRS181J-102X	MG RESISTOR		
	R 156	NRS181J-223X	MG RESISTOR				R 567	NRS181J-102X	MG RESISTOR		
	R 201	NRSA63J-471X	MG RESISTOR				R 568	NRS181J-102X	MG RESISTOR		
	R 202	NRSA63J-752X	MG RESISTOR				R 569	NRSA63J-102X	MG RESISTOR		
	R 251	NRS181J-183X	MG RESISTOR				R 570	NRSA63J-102X	MG RESISTOR		
	R 252	NRSA63J-123X	MG RESISTOR				R 571	NRSA63J-683X	MG RESISTOR		
	R 253	NRSA63J-273X	MG RESISTOR				R 572	NRSA63J-105X	MG RESISTOR		

■ Electrical parts list (Main board)

Block No. 01

△	Item	Parts number	Parts name	Remarks	Area
	R 573	NRSA63J-124X	MG RESISTOR		
	R 574	NRSA63J-331X	MG RESISTOR		
	R 701	NRSA63J-102X	MG RESISTOR		
	R 702	NRSA63J-151X	MG RESISTOR		
	R 703	NRSA63J-102X	MG RESISTOR		
	R 704	NRSA63J-151X	MG RESISTOR		
	R 705	NRSA63J-103X	MG RESISTOR		
	R 708	NRSA63J-822X	MG RESISTOR		
	R 725	NRSA63J-820X	MG RESISTOR		
	R 731	NRS181J-152X	MG RESISTOR		
	R 732	NRSA63J-102X	MG RESISTOR		
	R 733	NRSA63J-103X	MG RESISTOR		
	R 734	NRS181J-471X	MG RESISTOR		
	R 791	NRSA63J-103X	MG RESISTOR		
	R 792	NRSA63J-102X	MG RESISTOR		
	R 793	NRSA63J-103X	MG RESISTOR		
	R 794	NRSA63J-222X	MG RESISTOR		
	R 795	NRS181J-150X	MG RESISTOR		
	R 796	NRS181J-150X	MG RESISTOR		
	R 797	NRSA63J-100X	MG RESISTOR		
	R 798	NRSA63J-223X	MG RESISTOR		
	R 801	NRS181J-103X	MG RESISTOR		
	R 803	NRS181J-332X	MG RESISTOR		
	R 804	NRS181J-332X	MG RESISTOR		
	R 805	NRS181J-332X	MG RESISTOR		
	R 807	NRS181J-473X	MG RESISTOR		
	R 808	NRS181J-102X	MG RESISTOR		
	R 809	NRS181J-103X	MG RESISTOR		
	R 810	NRSA63J-104X	MG RESISTOR		
	R 811	NRSA63J-332X	MG RESISTOR		
	R 812	NRSA63J-332X	MG RESISTOR		
	R 813	NRSA63J-473X	MG RESISTOR		
	R 814	NRSA63J-473X	MG RESISTOR		
	R 815	NRSA63J-473X	MG RESISTOR		
	R 816	NRSA63J-473X	MG RESISTOR		
	R 817	NRS181J-472X	MG RESISTOR		
	R 818	NRS181J-473X	MG RESISTOR		
	R 822	NRSA63J-222X	MG RESISTOR		
	R 823	NRSA63J-473X	MG RESISTOR		
	R 825	NRS181J-473X	MG RESISTOR		
	R 826	NRSA63J-473X	MG RESISTOR		
	R 827	NRSA63J-473X	MG RESISTOR		
	R 828	NRSA63J-473X	MG RESISTOR		
	R 829	NRS181J-473X	MG RESISTOR		
	R 830	NRS181J-223X	MG RESISTOR		
	R 831	NRSA63J-472X	MG RESISTOR		
	R 832	NRS181J-223X	MG RESISTOR		
	R 833	NRSA63J-472X	MG RESISTOR		
	R 834	NRS181J-223X	MG RESISTOR		
	R 835	NRS181J-472X	MG RESISTOR		
	R 836	NRSA63J-473X	MG RESISTOR		
	R 861	NRS181J-471X	MG RESISTOR		
	R 862	NRS181J-471X	MG RESISTOR		
	R 902	QRZ0125-472X	C RESISTOR	4.7K 1/1W	
	R 903	NRSA63J-202X	MG RESISTOR		
	R 904	NRSA63J-104X	MG RESISTOR		
	R 905	NRSA63J-472X	MG RESISTOR		
	R 906	NRSA63J-472X	MG RESISTOR		
	R 907	NRSA63J-393X	MG RESISTOR		
	R 908	NRSA63J-683X	MG RESISTOR		
	R 909	NRSA63J-273X	MG RESISTOR		
	R 910	NRSA63J-473X	MG RESISTOR		
	R 911	NRS181J-473X	MG RESISTOR		

△	Item	Parts number	Parts name	Remarks	Area
	TU701	QAU0205-001	FM FRONT END		
	X 561	QAX0657-001Z	CRYSTAL		
	X 801	QAX0406-001Z	CRYSTAL		

■ Electrical parts list (LCD & Key control board) Block No. 02

△	Item	Parts number	Parts name	Remarks	Area
	C 601	NCB21HK-223X	C CAPACITOR		
	C 602	NCS31HJ-681X	C CAPACITOR		
	C 603	NBE20JM-106X	TS E CAP SVB20J		
	CJ601	VMC0335-001	CONNECTOR		
	D 601	LNJ308G81/1-3/X	LED		
	D 602	LNJ308G81/1-3/X	LED		
	D 603	LNJ308G81/1-3/X	LED		
	D 604	LNJ308G81/1-3/X	LED		
	D 605	LNJ308G81/1-3/X	LED		
	D 606	LNJ308G81/1-3/X	LED		
	D 607	LNJ308G81/1-3/X	LED		
	D 608	LNJ308G81/1-3/X	LED		
	D 609	LNJ308G81/1-3/X	LED		
	D 610	LNJ308G81/1-3/X	LED		
	D 611	LNJ308G81/1-3/X	LED		
	D 612	LNJ308G81/1-3/X	LED		
	D 613	LNJ308G81/1-3/X	LED		
	D 614	LNJ308G81/1-3/X	LED		
	D 615	LNJ308G81/1-3/X	LED		
	D 616	LNJ308G81/1-3/X	LED		
	D 617	LNJ308G81/1-3/X	LED		
	D 618	LNJ308G81/1-3/X	LED		
	D 619	LNJ308G81/1-3/X	LED		
	D 620	LNJ308G81/1-3/X	LED		
	D 621	SML-310LT/MN/-X	LED	POWER LED	
	D 641	MA3051/M/-X	ZENER DIODE		
	D 642	MA152WK-X	SI DIODE		
	IC601	LC75823W	IC		
	PL601	QLL0056-001	PILOT LAMP		
	PL602	QLL0056-001	PILOT LAMP		
	R 601	NRSA02J-681X	MG RESISTOR		
	R 602	NRSA63J-511X	MG RESISTOR		
	R 603	NRSA02J-681X	MG RESISTOR		
	R 604	NRSA02J-911X	MG RESISTOR		
	R 605	NRSA02J-122X	MG RESISTOR		
	R 606	NRSA02J-681X	MG RESISTOR		
	R 607	NRSA63J-511X	MG RESISTOR		
	R 608	NRSA63J-681X	MG RESISTOR		
	R 609	NRSA63J-911X	MG RESISTOR		
	R 610	NRSA63J-122X	MG RESISTOR		
	R 611	NRSA63J-152X	MG RESISTOR		
	R 612	NRSA02J-222X	MG RESISTOR		
	R 613	NRSA63J-681X	MG RESISTOR		
	R 614	NRSA63J-511X	MG RESISTOR		
	R 615	NRSA02J-681X	MG RESISTOR		
	R 616	NRSA63J-911X	MG RESISTOR		
	R 617	NRSA02J-122X	MG RESISTOR		
	R 618	NRSA02J-152X	MG RESISTOR		
	R 631	NRSA02J-821X	MG RESISTOR		
	R 632	NRSA02J-271X	MG RESISTOR		
	R 633	NRSA02J-271X	MG RESISTOR		
	R 634	NRSA02J-271X	MG RESISTOR		
	R 635	NRSA02J-271X	MG RESISTOR		
	R 636	NRSA02J-271X	MG RESISTOR		
	R 637	NRSA02J-271X	MG RESISTOR		
	R 638	NRSA02J-271X	MG RESISTOR		
	R 639	NRSA02J-271X	MG RESISTOR		
	R 640	NRSA02J-271X	MG RESISTOR		
	R 641	NRSA02J-271X	MG RESISTOR		
	R 651	NRSA63J-222X	MG RESISTOR		
	R 652	NRSA63J-222X	MG RESISTOR		
	R 653	NRSA63J-103X	MG RESISTOR		
	R 654	NRSA63J-103X	MG RESISTOR		

△	Item	Parts number	Parts name	Remarks	Area
	R 655	NRSA63J-103X	MG RESISTOR		
	R 656	NRSA02J-103X	MG RESISTOR		
	R 657	NRSA63J-513X	MG RESISTOR		
	R 658	NRSA63J-184X	MG RESISTOR		
	S 601	NSW0124-001X	TACT SW	POWER	
	S 602	NSW0124-001X	TACT SW	VOL UP	
	S 603	NSW0124-001X	TACT SW	VOL DOWN	
	S 604	NSW0124-001X	TACT SW	LOUD	
	S 605	NSW0124-001X	TACT SW	MO	
	S 606	NSW0124-001X	TACT SW	DOWN	
	S 607	NSW0124-001X	TACT SW	SELECT	
	S 608	NSW0124-001X	TACT SW	UP	
	S 609	NSW0124-001X	TACT SW	1	
	S 610	NSW0124-001X	TACT SW	2	
	S 611	NSW0124-001X	TACT SW	3	
	S 612	NSW0124-001X	TACT SW	4	
	S 613	NSW0124-001X	TACT SW	5	
	S 614	NSW0124-001X	TACT SW	EJECT	
	S 615	NSW0124-001X	TACT SW	6	
	S 616	NSW0124-001X	TACT SW	DISPLAY	
	S 617	NSW0124-001X	TACT SW	SCAN	
	S 618	NSW0124-001X	TACT SW	SOUND	
	S 619	NSW0124-001X	TACT SW	AM	
	S 620	NSW0124-001X	TACT SW	FM	
	S 621	NSW0124-001X	TACT SW	CD	

< MEMO >

Packing materials and accessories parts list

Block No.

M	3	M	M
---	---	---	---

Block No.

M	4	M	M
---	---	---	---

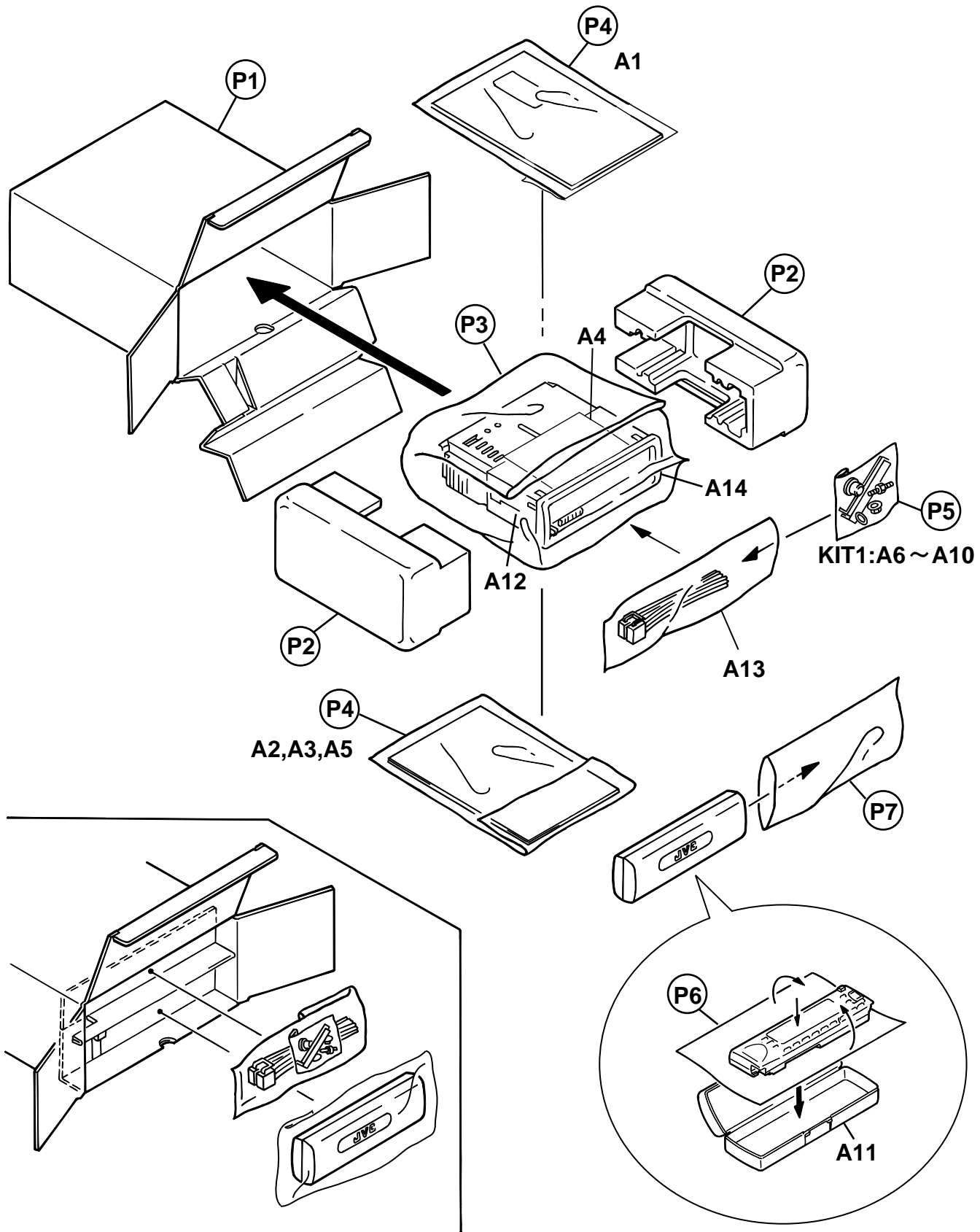

Parts list (Packing)

Block No. M3MM

△	Item	Parts number	Parts name	Q'ty	Description	Area
	P 1	GE30123-031A	PACKING CASE	1		
	P 2	GE10008-001A	PACKING CUSHION	2		
	P 3	QPC03004315P	POLY BAG	1	FOR SET	
	P 4	FSPG4002-001	POLY BAG	2	FOR INST BOOK	
	P 5	QPA00801205	POLY BAG	1	FOR SCREW KIT	
	P 6	FSYH4036-068	SHEET	1	FOR HARD CASE	
	P 7	QPA01003003	POLY BAG	1	FOR HARD CASE	

Parts list (Accessories)

Block No. M4MM

△	Item	Parts number	Parts name	Q'ty	Description	Area
	A 1	GET0005-001A	INST BOOK	1	ENG GER FRE DUT	
	A 2	GET0005-002A	INST BOOK	1	SPA ITA SWE FIN	
	A 3	GET0005-003A	INSTALL MANUAL	1	ENG GER FRE	
		GET0005-004A	INSTALL MANUAL	1	DUT SPA ITA	
		GET0005-005A	INSTALL MANUAL	1	SWE FIN	
	A 4	LV40978-001A	CAUTION SHEET	1		
	A 5	BT-54013-1	WARRANTY CARD	1		
	A 6	VKZ4027-202	PLUG NUT	1		
	A 7	VKH4871-001SS	MOUNT BOLT	1		
	A 8	VKZ4328-001	LOCK NUT	1		
	A 9	WNS5000Z	WASHER	1		
	A 10	FSKL4010-002	HOOK	2		
	A 11	FSJB3001-30C	HARD CASE	1		
	A 12	FSKM2004-202	MOUNTING SLEEVE	1		
	A 13	QAM0089-001	16P CORD ASSY	1		
	A 14	FSJD2034-001	TRIM PLATE	1		
	KIT 1	KDGS717K-SCREW1	SCREW PARTS KIT	1	A5-A9	